

2025 REVISION TABLE

(To the 2024 Electric Line Extension and Service Standards)

From, Type, Reason	CHAPTER	TITLE	REVISION DESCRIPTION
URR Tariff, Update wording based on updated to the 2025 URR Tariff language.	3.03	Overhead and Underground Electric Facilities	The costs of the extension will be collected with an <i>Extension Contract</i> or a <i>Revenue Guarantee Recovery Agreement Contract</i> . The Utilities Rules and Regulations, Electric <u>Line Extensions and Services Section 2.A(1)</u> , determine when a <i>Recovery Agreement Revenue Guarantee Contract</i> shall be applied to requests for extensions. When, in the sole judgment of Utilities, the costs to administer a <i>Recovery Agreement Revenue Guarantee Contract</i> are prohibitive, an <i>Extension Contract</i> will be administered. Total project costs will be included if a <i>Recovery Agreement Revenue Guarantee Contract</i> is administered.
Christopher Sine, Minimum conduit size for above ground vs below ground CT metering conduit.	5.04a7	Instrument Transformer (CTs & VTs) Metering	CT metering conduits, when required, shall be <u>a minimum 1-1/2" inch for above grade conduit and a minimum 2 inch for below grade conduit</u> size from the transformer pad or CT cabinet to the meter socket, continuous run of either GRC or schedule 40 PVC, with all exposed above ground lengths to be schedule 80 PVC or GRC terminated with grounding bushings bonded to local ground electrodes.
Christopher Sine, Line/ Load Side feed on Overhead vs Underground Services	5.04c6	Instrument Transformer (CTs & VTs) Metering/ CT Cabinets	The line side must be fed from the top of the CT cabinet, with the load side fed from the bottom <u>only on Overhead services, Underground services may be installed with the line side from the bottom or top.</u>
Christopher Sine, -Minimum conduit size for above ground vs below ground CT metering conduit. -Changed Maximum CT Conduit run length from 35' to 20'.	5.04e	Instrument Transformer (CTs & VTs) Metering/ Instrument Transformer Conduit	- In all instrument transformer metering cases, the customer will furnish and install a minimum 1-1/2 inch <u>for above grade conduit and a minimum 2 inch for below grade conduit</u> , between the meter socket and the instrument transformer (CT & VT) location for use by Colorado Springs Utilities. - The maximum distance (total length of conduit run <u>including all bends</u>) will be 35 <u>20</u> feet with no more than three 90-degree bends in a single pull section.
Bill Galloway and Lisa Ross, Add reference to GLESS Chapter 3 for LUSI Rules and Procedures	7.02	Residential Underground System	For gas service line installation requirements and procedures , Refer to Gas Line Extension & Service Standards book, latest edition, <u>Chapter 3 for the "Utility Service Installer License Rules and Procedures" and Chapter 4 for gas service line installation requirements and procedures</u> , including Appendix C - Table 7 for approved materials, Appendix C - Table 44 <u>10</u> for Inspection Checklist, and Appendix D - Figures 4-9 for installation details.

2025 REVISION TABLE

(To the 2024 Electric Line Extension and Service Standards)

Lisa Ross and Tim Benedict, Update wording for Overtime contract	8.07 & 8-10	Request for Colorado Springs Utilities to Work Overtime	8.07: Rewording of process for developer or other customer to request a Time & Material Overtime Request. 8-10: It is understood that any money paid for overtime work is not part of the base contract and is nonrefundable not recoverable .
URR Tariff, Update wording based on updated to the 2025 URR Tariff language.	10.01f1	Commercial Underground System/ Customer Installation Requirements in an Underground Area	Due to additional costs of undergrounding a distribution system, partial participation in the installation of the electrical distribution system will be required of the customer. All such work must be done by a licensed electrical contractor at the customer's expense. Appropriate mainline-extension recovery agreement and aid-to-construction fees may apply.
Toby Mijares, Downtown Network customer owned secondary cable limiters.	10.06c3g	Colorado Springs Network Service Area/ Electrical System Design	Added bullet g recommending the installation of cable limiters on customer owned secondary cable and busses on the grid network. Wording is likely to change on this, will be discussed in the next downtown network meeting.
Rick Whitehair II, Customer inverter assessed for settings and optional Volt-VAR setpoints	13.04c6	Generators Continuously Paralleled /Voltage Control & Flicker	6) Normally, the generated voltage shall follow, not attempt to oppose or regulate, changes in the prevailing voltage level provided by Utilities at the PCC in accordance with IEEE 1547. <u>The customer may be required to coordinate with Utilities Engineering on a prescribed volt/VAR or power factor schedule. All solar or generation projects with an inverter will be assessed for optional advanced inverter settings during the application process. These settings including Volt-VAR setpoints and if required will be communicated to the customer, installer, and other application stakeholders.</u>
Bryce Reher, Installation Requirements, updates to 193-SPP-SCA Specifications	13.08c	Meter Installations at Primary Metered Generation Sites 150 kW and Above	Updates to the process of installing generation power plant SCADA panels for sites equal to or greater than 500 kW. Allow for concrete pads as well as vaults.
Tim Thomas, Appendix B updates	Appendix B	Appendix B, Utilities Addressing Plan, Utilities Design CAD File and Easements Policies and Procedures	Acronym, phone number and added additional clarification notes.
Toby Mijares, Added TESCO Metering Cabinets and Eaton Cable Limiters.	Appendix C, Table 3	Material Requirements for Use In Electric Service Line Construction	<ul style="list-style-type: none"> •Added TESCO metering cabinets as approved models for 8 Terminal and 13 Terminal Pre wired meter sockets with test switches. •Added Eaton cable limiters as approved for downtown network.

2025 REVISION TABLE

(To the 2024 Electric Line Extension and Service Standards)

Christopher Sine, -Minimum conduit size for above ground vs below ground CT metering conduit. -Changed Maximum CT Conduit run length from 35' to 20'.	Appendix D, (Various)	(Various)	-Appendix D, Drawings 12A, 12B, & 13: 18" RADIUS 90° ELBOW AND CONDUIT (MIN 2" PVC BELOW GRADE) -Appendix D, Drawings 14 & 15: 1-1/2" SCH80 PVC OR GRC- 20' MAX,OR EMT- 2' MAX -Appendix D, Drawing 19: 20' MAX and note 7: The CT meter conduit shall be no longer than 20 feet (total length of conduit including all bends)
Christopher Sine, Line/ Load Side feed on Overhead vs Underground Services	Appendix D, Photo 1	PHOTO 1 – THREE PHASE CT CABINET	<u>For Overhead Services, Line Side must be on Top. For Underground Services, Line Side may be on the Bottom or Top.</u>
Elizabeth Ritchey, Clarify color options for AC Disconnect Switch	Appendix D, Photo 6	PHOTO 6 – PHOTOVOLTAIC SERVICE EQUIPMENT LABELING	Customer Provided “AC Disconnect” Placard on AC Disconnect Switch. <u>Color may be black text on yellow background or white text on red background.</u>
Toby Mijares, Updated specification 102-600-077	Appendix E, Material Specification	102-600-070 & 102-600-077 Socket, Meter, Prewired Test Switch, 8 & 13 Terminal, 20 Amp	Updated Material Specification 102-600-070 & 102-600-077 Socket, Meter, Prewired Test Switch, 8 & 13 Terminal, 20 Amp
Toby Mijares, Add specification 102-700-(000-001) to Appendix E	Appendix E, Material Specification	102-700-(000-001) Switch, Color Coded Meter Test – (VARIES) Connected	Add Material Specification 102-700-(000-001) “Switch, Color Coded Meter Test – (VARIES) Connected” to Appendix E.
Bill Galloway and Adrian Pereida, Add specification 193-SPP-SCA to Appendix E	Appendix E, Material Specification	193-APP-SCA Generation Power Plant SCADA Panels	Add Material Specification 193-SPP-SCA “Generation Power Plant SCADA Panels” to Appendix E.
Updated notes in reference to conformance with City of Colorado Springs Public Works specifications.	Appendix F, 11-1	Trenching, Backfill/Compaction, Concrete Mixes, & Aggregate Base Course Materials	-Deleted notes 1 & 2 and moved note 6 to note 1 position. -Revised note 1 as follows: “ <u>All work to be</u> in conformance with City of Colorado Springs Public Works specifications <u>(https://coloradosprings.gov/public-works/page/standard-specifications-manual)</u> . Refer to other authority if using state highway or county roads.”
Updated notes and drawings for Fiber conduit and tracer wire. Added note about trench marking tape.	Appendix F, 11-2	Concrete Encased Duct Banks	-Updated notes and drawings for Fiber conduit and tracer wire. -Added trench marking tape note to drawing: <u>“INSTALL TWO RUNS OF 3" RED CAUTION TAPE, 12" ABOVE DUCT & 1' APART (#100-136-036)”</u>

2025 REVISION TABLE

(To the 2024 Electric Line Extension and Service Standards)

Added new section for Fiber Conduit.	Appendix F, 11-5	Tracer Wire for Empty Ducts	Added new section for Fiber Conduit.
Revised exception note about 3' clearance to Fiber, added note about horizontal clearance to fiber boxes, & updated note 2 for Joint trench with Utilities' Fiber.	Appendix F, 18-304	Clearances Of Ug Electric Conduit/Cable from Other Facilities	<p>Reformatted wording for Exception "e" that reduces clearance Telecom/ fiber to 3' when the requirements listed are met, emphasized the past requirement that high pressure gas main requires a 10-foot horizontal clearance with no exceptions, and added text "<u>The horizontal clearance distance applies to fiber appurtenances, to include boxes (boxes must be the required horizontal and vertical distance away from gas and electric and shall not be placed over electric or gas pipe).</u>"</p> <p>Updated note 2: "These clearance matrix table dimensions are for separate trenches. <u>Joint trench between Gas and Colorado Springs Utilities Telecom./ Fiber requires a 1' radial separation. Joint trench between Electric and Colorado Springs Utilities Telecom./ Fiber requires a 3" in concrete and 6" in fill earth radial separation.</u>"</p>
-Updated Phone List	Phone Numbers & Contact Information	Phone Numbers & Contact Information	Updated Phone List and FE Maps.

CHAPTER 3

Electric Service Limitations and Voltage Standards

3.01 General:

Electric service connections are limited to electric energy supply and transmission substation and distribution facilities available at time of building construction. Available secondary service voltage classifications will depend upon a customer's location and proximity to existing facilities within an overhead or underground service area.

The standard secondary service is alternating current, 60 hertz, single phase or three-phase. Service must not be used by the customer for purposes other than those specified in the applicable Electric Tariffs. The standard voltage classification for residential service is 120/240 volt single-phase or 120/208 volt two-phase.

3.02 Overhead and Underground Service Area Secondary Voltages:

Single-phase, two-wire, 120 volts.

Single-phase, three-wire, 120/240 volts.

Two-phase, three-wire, 120/208 volts wye.

Three-phase, four-wire, 120/208 volts wye.

Three-phase, four wire 277/480 volts wye.

3.03 Overhead and Underground Electric Facilities:

The electric distribution and transmission system is composed of overhead and underground electrical facilities.

As required by City Code, electric distribution facilities will be placed underground in areas subdivided and platted after 1967 within the corporate limits of the City of Colorado Springs pursuant to the operating rules and regulations of Colorado Springs Utilities.

New electric transmission facilities will typically be constructed overhead [in accordance with the Utilities Board motion 10.18.2023]. Consideration for placement underground will be made on a case-by-case basis where overhead line congestion or other factors necessitate. Underground construction of 115kV transmission lines may also occur under a System Improvement Program agreement as described in Chapter 11, System Alteration and Conversion.

In areas containing existing overhead distribution, it is Utilities policy to extend and pay for a maximum of two spans of overhead distribution system. The customer is responsible for the costs of any additional extension. The costs of the extension will be collected with an *Extension Contract* or a ~~*Revenue Guarantee-Recovery Agreement Contract*~~. The Utilities Rules and Regulations, Electric [Line Extensions and Services Section 2-A\(1\)](#), determine when a ~~*Recovery Agreement Revenue Guarantee Contract*~~ shall be applied to requests for extensions. When, in the sole judgment of Utilities, the costs to administer a ~~*Recovery Agreement Revenue Guarantee Contract*~~ are prohibitive, an *Extension Contract* will be administered. Any funds deposited with the *Extension Contract* will be identified as contributions-in-aid-to-construction and are not eligible for refund. The *Extension Contract* will not include the costs of the first two spans of the extension. Total project costs will be included if a ~~*Recovery Agreement Revenue Guarantee Contract*~~ is administered.

side conductors in CT cabinet must be terminated prior to utilities wiring of instrument transformers and sockets.

- 6) Any exception to the instrument transformers (CTs & VTs) metering practices outlined above or below will require written approval of Colorado Springs Utilities Advanced Metering Technologies Group Supervisor prior to installation (see Phone Section).
- 7) CT metering conduits, when required, shall be a minimum 1-1/2" inch for above grade conduit and a minimum 2 inch for below grade conduit size from the transformer pad or CT cabinet to the meter socket, continuous run of either GRC or schedule 40 PVC, with all exposed above ground lengths to be schedule 80 PVC or GRC terminated with grounding bushings bonded to local ground electrodes.

b) Instrument Transformers In Padmount Transformers:

When a three-phase padmount transformer supplies a single-metered customer with service entrance rating greater than 1200 amps, the metering CTs & VTs must be located in the secondary compartment of the padmount transformer. The customer will install a conduit from the meter socket location to the padmount transformer secondary compartment as noted in 5.04e. Metering conduit shall be installed in front of secondary conduits. A pull line will be provided, for pulling instrument transformer wire. See Appendix D, Drawings 12 & 13 for typical instrument transformer metering in padmount installations. Instrument transformers (CTs & VTs) will not be installed in single-phase padmount transformers. Instrument transformers (CTs & VTs) mounted in padmount transformers will be installed by Colorado Springs Utilities prior to, or at the time of, delivery of the transformer to the job site.

c) CT Cabinets:

Where CT cabinets are required, they will be furnished and installed on the outside of an exterior wall by the customer (see 5.02c for exceptions).

All residential single-phase CT metered installations shall be wired using two bar-type CTs. The size of the cabinet shall allow a minimum bending space in accordance with Section 312 of the National Electrical Code. If the service wires enter the cabinet, terminate directly on the CTs and exit on the opposite side, then minimum cabinet dimensions shall be 18" wide x 24" high x 10" deep. This cabinet will accommodate installations with a maximum of two 350-kcmil conductors per phase. The Colorado Springs Utilities Field Engineer will designate a point to which a customer shall install either (1) 3 inch or 4 inch conduit from the CT's at a depth of 36 inches- typically to a j-box or transformer (SCH80 PVC or GRC above ground, PVC below ground). All commercial CT cabinets must be a minimum of 30" wide x 30" high x 10" depth regardless of voltage.

All commercial and residential CT cabinets shall meet the following requirements:

- 1) CT cabinets requiring three CTs shall measure a minimum of 30" wide x 30" high x 10" deep.
- 2) Rated and factory labeled "NEMA 3R".
- 3) Rated 600 volts maximum and shall have a grounding lug.
- 4) Doors shall be supplied with a hasp to accept a Colorado Springs Utilities padlock (5/16 inch diameter shackle). All raceways and compartments ahead of the cabinet shall also be sealable. No breakers, fuses, or other customer accessible equipment is allowed in the

- 5) Incorporate a provision (lug or terminal) for bonding together line and load side service neutrals with electrical bond to the cabinet. If the CT cabinet is on the load side of the main disconnect, where the neutral is already grounded, do not bond neutral block to the CT cabinet (see Appendix D, Drawing 17). This termination shall also include a terminal for connecting #12 AWG solid or stranded copper wire to the neutral conductor within the enclosure for purpose of providing a secondary neutral to the meter.
- 6) CT cabinets shall be installed immediately adjacent to the associated meter socket(s). A minimum clearance will be provided in front of the CT cabinet to fully open the door and have at least 3 feet of working space. The maximum height to the top of a CT cabinet will not exceed 7 feet above finished grade. Physical location of the CTs must be centered between 48 inches and 72 inches above finished grade. CTs must be installed with the white dot (H-1) facing the line side. The line side must be fed from the top of the CT cabinet, with the load side fed from the bottom only on Overhead services, Underground services may be installed with the line side from the bottom or top. The contractor will be required to label the line side and load side of the CT cabinet. The line and load sides shall be marked accordingly as "LINE" or "LOAD". The "VT Pack" is to be installed per Advanced Metering Technologies Group specifications (see 5.04a2), so that the connection point (plug) is accessible for installation of the wiring harness. No other meter devices or customer equipment will be allowed within the CT cabinet. Any variance requires written approval from the Colorado Springs Utilities Advanced Metering Technologies Group Supervisor (see Phone Section). See Appendix D, Drawing 14 and Photos 1, 2, 3 and 4 for a typical CT cabinet installation.

d) Instrument Transformers (CTs & VTs) In Customer Switchgear:

1) General:

Under unique circumstances, approval to install instrument transformers (CTs & VTs) in a customer's switchgear may be granted by the Colorado Springs Utilities Advanced Metering Technologies Group Supervisor. Such approval will be provided in writing for each individual installation in the comments area on the customer reply sheet of the load data form. Approval will depend on whether or not routine work, e.g. shunting and replacing of CTs, can be accomplished in a safe manner consistent with Colorado Springs Utilities safe work practices, as well as on accessibility for routine maintenance and inspection. Such instrument transformer (CT & VT) installations will be outdoors in a location considered readily accessible during normal working hours, e.g. in a public parking garage. If a "VT Pack" is needed, it is to be installed so that the connection point (plug) is accessible for installation of the wiring harness (see 5.04a2). The minimum size for the instrument transformer (CT) compartment for a 120/208V service shall be 30" wide x 30" high x 10" deep. The minimum size for the instrument transformer (CT & VT) compartment for a 277/480V service shall be 30" wide x 30" high x 10" deep to accommodate both the CTs and the VTs (VTs are required for 277/480v services only). On 277/480 volt services, when the CT cabinet is not large enough to accommodate the VT Pack, then a sealable external VT Pack enclosure will be required with a minimum size of 18" wide x 18" high x 8" deep. Rigid conduit will be run from the instrument transformer (CT & VT) compartment or section to the meter socket location as noted below. All raceways and compartments ahead of the metering will be sealable by Colorado Springs Utilities, including the CT section. Barriers shall be provided between the CT, VT, or meter compartments and other customer accessible compartments. See Appendix D, Drawings 12 & 13 for typical instrument transformer (CT & VT) metering installations.

Appendix D, Drawings 12 & 13 for typical instrument transformer (CT & VT) metering installations.

2) Outdoor Commercial Switchgear Metering Option:

Commercially available multi-meter switchgear meeting Colorado Springs Utilities requirements in Appendix D, Drawing 19 is approved for optional use in the Colorado Springs Utilities Electric Distribution System for commercial services. Metering switchgear is an option to be provided, installed and maintained by the customer at an outdoor location that is readily accessible by Colorado Springs Utilities. The metering switchgear shall include mounting provisions for instrument transformers (CTs & VTs) and metering equipment with phase/neutral terminals for a #12 copper potential connection. CT/VT compartments shall meet all requirements of section 5.04, however, the CT's may be mounted as low as 36" for double stacked CT compartments.

e) Instrument Transformer Conduit:

In all instrument transformer metering cases, the customer will furnish and install a minimum 1-1/2 inch for above grade conduit and a minimum 2 inch for below grade conduit, between the meter socket and the instrument transformer (CT & VT) location for use by Colorado Springs Utilities. All such conduit above ground and accessible to pedestrians will be schedule 80 PVC or galvanized rigid steel conduit (SCH80 PVC or GRC). The maximum distance (total length of conduit run including all bends) will be 35-20 feet with no more than three 90-degree bends in a single pull section. Colorado Springs Utilities will install and terminate conductors from the instrument transformer (CT & VT) secondary to the meter socket using the customer-furnished conduit; the customer will not install any conductors except for ground wire as shown in Appendix D, Drawing 17, in this conduit. This conduit must be contiguous from the meter socket to the switchgear CT cubicle (See Appendix-D, Drawing 19). The customer shall install a pull line for pulling instrument transformer (CT & VT) wire.

5.05 Self-Contained Meter Sockets:

a) Codes and Standards:

- 1) All meter sockets, meter stacks, and modular metering systems will be manufactured in accordance with the latest revision of the following:
ANSI C.12.7, ANSI/UL 50, ANSI/UL 414, and NEMA 250, as well as all other applicable code and Standards, with revisions and modification as contained in this specification.
- 2) All meter sockets used on the Colorado Springs Utilities electric system shall conform to the following requirements. Colorado Springs Utilities personnel have been instructed not to install a meter at a location where the meter socket does not comply with ALL of the following criteria. See also Chapter 5, 5.15 "Meter Sets for Approved Meter Sockets".
- 3) For questions regarding these requirements, contact the Advanced Metering Technologies Group Supervisor (see Phone Section).

b) Electrical Ratings:

- 1) All sockets/housings shall be rated 300V or 600V as detailed in ANSI C.12.7.
- 2) Minimum socket ampacity rating:

Continuous Socket Application	Continuous Ampacity Rating
Residential (single residence overhead service)	100

Electrical Code and Regional Building Department requirements at the customer's expense.

7.02 Residential Underground System:

In locations where Colorado Springs Utilities has installed an underground distribution system, Colorado Springs Utilities has three types of residential underground services with various areas of responsibility. The three main types are: Residential developments that are joint trench with gas (subdivision installations), Residential developments or Individual applications for service that are not joint trench with gas and Residential services rated greater than 200 amps. Refer to Chapter 8 for additional requirements for an underground residential development.

- On residential developments that utilize a joint trench for Colorado Springs Utilities' electric service lines and gas services: The customer shall hire a Licensed Utility Service Installer that is responsible for providing and installing the trenching, padding & backfilling, underground conduit (if required), electric service conductor and gas service lines to the building foundation. The customer's licensed electrician will install the service conductor from the building foundation to the meter socket, per Colorado Springs Utilities standards. ~~For gas service line installation requirements and procedures,~~ Refer to Gas Line Extension & Service Standards book, latest edition, Chapter 3 for the "Utility Service Installer License Rules and Procedures" and Chapter 4 for gas service line installation requirements and procedures, including Appendix C - Table 7 for approved materials, Appendix C - Table ~~4-10~~ for Inspection Checklist, and Appendix D - Figures ~~1-9~~ for installation details.
- On residential developments or individual applications for service, that will not utilize a joint trench for Colorado Springs Utilities' electric service lines and gas services: The customer or the customer's licensed electrician is responsible for providing and installing the trenching, padding & backfilling and conduit. The customer's licensed electrician will furnish and install the service conductor per Colorado Springs Utilities standards.
- For services rated greater than 200 amps, the customer's licensed electrician is responsible for providing and installing the trench, padding & backfill, conduit and service conductor. A Load Data Form must be submitted to Colorado Springs Utilities Field Engineering for required service design details which are necessary to assure that sufficient transformer capacity, appropriate conductor size, and metering requirements are provided by Colorado Springs Utilities. The process for services greater than 200 amps parallels the commercial process noted in Chapter 10 with the exception that the service conductor must meet Colorado Springs Utilities conductor standards. See 7.02 a3 and Chapter 10 for additional details.

Colorado Springs Utilities will own, and maintain all residential underground services up to the meter except as designated in this Chapter.

Permanent meter requests are to be initiated by contacting the Colorado Springs Utilities Customer Service. Colorado Springs Utilities must be notified reasonably in advance of required installation. Electric service fees will be paid prior to issuance of a building permit.

Grading, excavation, ground rod, stake or post installation work will not be started until an underground facilities location has been completed. Call 811 for utility locates. See 2.03b for Underground locate requirements.

a) Underground Electric Service Requirements:

- 1) For all services the customer will be responsible for:
 - (a) Bring the lot to final grade.
 - (b) Remove all obstacles, such as piles of lumber, brick, etc.

c) Trenching and Boring of Conduit:

- 1) If required depth of trench or bored-in conduit cannot be met, new proposed depth must be approved in advance by Utilities inspector.
- 2) Potholing may be required, at the discretion of Utilities inspector, to prove the need for any excessive depth proposed, prior to approval.
- 3) Conduit will be required for any installation that exceeds Utilities maximum depth as shown in Electric Distribution Construction Standard 11-1 (see Appendix-F).

8.07 Request for Colorado Springs Utilities to Work Overtime:

Developers or other customers may request for a Gas or Electric Extension Crew (Colorado Springs Utilities/Contractor) to work overtime (OT) on their projects. Colorado Springs Utilities reserves the right to select the crew based on operational and contractual obligations.

The Developer or other customer must complete and submit to Colorado Springs Utilities Field Engineering a T&M Overtime Request Letter with relevant information filled in (see form at end of ~~chapter 8~~this chapter). ~~These~~ request letters ~~are is also~~ available from Colorado Springs Utilities Quality Control Inspectors, Colorado Springs Utilities Crew Supervisors or Colorado Springs Utilities Field Engineering representatives. The OT requests are typically discussed and completed at pre-construction meetings. If an overtime request is approved (contingent upon crew availability), Colorado Springs Utilities will create an Overtime T&M work order for the actual OT cost. Field Engineering will reconcile the OT costs upon completion of the project.

~~If an overtime request is approved (contingent upon crew availability), Field Engineering will create a Flat Rate T&M contract.~~

~~All monies for OT work that is requested and approved must be collected before construction can start, without exception. The Developer or customer must know and make payment for hours of OT the crew will work. There will be no reconciliation after the project and crews will only work for hours paid in full. Therefore, the precise number of hours to be worked needs to be known at the time of the request.~~

~~Field Engineering can supply the hourly crew rate (adjusted annually in May) that will cover the total labor rate for the crew to include typical equipment used.~~

~~If special conditions exist that require extra personnel or specialized equipment for construction Field Engineering may apply additional charges to the flat rate.~~

The money received by Colorado Springs Utilities Field Engineering will be deposited as Aid to Construction at the respective Field Engineering office. ~~Call~~Contact Colorado Springs Utilities Field Engineering at 668-3574 with ~~any~~ questions (see Contact Section).

Request Form for Colorado Springs Utilities to Work Overtime

Date _____

Re: **T&M Overtime Request**

Colorado Springs Utilities

Field Engineering- North Work Center
7710 Durant Drive
Colorado Springs, CO 80920

Field Engineering- South Work Center
1521 Hancock Expressway
Colorado Springs, CO 80903
Email: UtilityApplication@csu.org

Dear Colorado Springs Utilities:

This is a request for the Gas & Electric Extension Crews (Colorado Springs Utilities or Contractor) to work overtime on _____ Subdivision (project name and filing number). Overtime will only be worked as resources are available. The overtime worked will help expedite the process of the installation of the gas and electric extension, which is needed at this time. It is understood that any money paid for overtime work is not part of the base contract and is ~~non-refundable~~ not recoverable.

Thank you for your assistance in this matter. If you have any questions, please contact me at _____.

Sincerely,

_____ (print name)

_____ (title)

_____ (company name)

_____ (billing address)

_____ (requested number of overtime hours)

_____ (date(s) for requested overtime)

Electrical Materials, and Appendix-E for specification 194-2 regarding “Polyethylene Conduit for Underground Installation”.

(b) The minimum acceptable wire size for minor load, metered or non-metered loops is:

- (1) #6 copper or aluminum.
- (2) This will apply to both neutral and phase conductors.
- (3) Any insulation type approved for designated use by the National Electrical Code is acceptable.

(c) By-pass jaws are not required on meter sockets for minor loads.

3) Non-metered Single-Phase Services:

(a) Non-metered services are available through our Non-Metered Tariff with an average daily usage that on a per device basis cannot exceed 1,000 kWh within a single monthly billing period and the equipment is located within the public right-of-way. Alternatively, a non-metered service is available only after a customer has met and agreed to the requirements for a commercial non-metered electric load and has signed a Nominal Load Contract/Agreement with Colorado Springs Utilities. The rate is based on the amount of energy used, which may not exceed 33kWh per day for the Non-Metered Tariff or 66kWh per day for a Nominal Load Contract/Agreement. The Non-Metered Tariff is subject to City Council approval (estimated to be completed by December 31, 2021).

(b) For unmetered 120V load tap services, the contractor is required to install either a 10A circuit breaker for 900 Watt services, or a streetlight fuse kit, sized for the load requirements. See Appendix F EDCS 8-7 for construction details, and Appendix C Table 3 for approved materials.

f) Customer Installation Requirements in an Underground Area:

- 1) Due to additional costs of undergrounding a distribution system, partial participation in the installation of the electrical distribution system will be required of the customer. All such work must be done by a licensed electrical contractor at the customer’s expense. Appropriate ~~mainline extension~~ recovery agreement and aid-to-construction fees may apply. A design fee will be collected by Utilities Development Services at time of building permit. The current Electric Tariffs, as adopted by City Council, should be consulted.
- 2) The customer will be responsible to install the electrical distribution facilities within the private property adhering to Colorado Springs Utilities design policies and all applicable codes. Installations by the customer creating noncompliance with Colorado Springs Utilities policies and/or applicable electrical codes will be relocated as necessary at the sole expense of the customer. Transformers and switches will be located to be accessible from the street, driveway, or parking area without obstruction. Primary distribution or secondary services will not pass under any form of structure. When a transformer is remote from the street, the customer will provide a driving surface no less than 10 feet wide to within 12 feet of a transformer location. Acceptable materials for a driving surface include concrete, asphalt, architectural pavers and aggregate base course. For aggregate base course, the top six (6) inches of topsoil shall be stripped with a width approximately 5’ wider than driving surface road width. Fill 6” and taper approximately 2.5’ on both sides. Aggregate base

service or changing an existing service within the Network System boundaries. Long lead times for network equipment may affect the Customer's service date. Alterations and additions to this System generally require a great deal of time and coordination between Colorado Springs Utilities and the Customer.

c) Electrical System Design:

- 1) After the load data form has been received, Colorado Springs Utilities will reply with a letter stating the fault current on the Network System. The fault currents are higher in the Network System because there are multiple sources paralleled together serving the secondary wires that serve the Customer. Diversified demands and metering requirements will be provided to the Customer.
- 2) Colorado Springs Utilities limits the capacity to any "spot" Customer on the Network System to 2000 kVA diversified load and limits the capacity to any "grid" building on the Network System to 300 kVA diversified load. If the "grid" building has multiple services, the load of the building is still limited to 300kVA diversified. In the event the requested service is higher than these limits, Colorado Springs Utilities will work with the Customer on a case by case basis to meet their needs. This may require alternatives to Network service.
- 3) Grid (208Y/120):
 - (a) A "grid" Network System has its (208Y/120 volt) secondaries paralleled together and serves small loads located within the boundaries of the network.
 - (b) Maximum allowable load to any new or existing Customer will be up to 300 kVA diversified load. Colorado Springs Utilities is no longer expanding the areas served by the "grid". Each request will need to be evaluated due to the age and design of the Network System. Please contact the South Area Field Engineering Section (see Phone Section) for information.
 - (c) The point of common coupling is determined by Colorado Springs Utilities. The point of common coupling for the Network System will differ from typical commercial installations. The Customer is responsible for the service from the service entrance up to the point of common coupling. The point of common coupling may be from a vault or possibly back to the transformer.
 - (d) The Customer shall be responsible for purchase, installation, and maintenance of the service lateral conduits in accordance with Colorado Springs Utilities' specifications from the point of common coupling to the Customer's service entrance. Colorado Springs Utilities' personnel shall directly supervise all work involving Customer penetration into Colorado Springs Utilities' equipment (handhole, manhole, or vault).
 - (e) Secondary cable permitted in the Network System is 600 volt class, rated for wet locations, a temperature of 90 degree C. Secondary cable shall be approved by Colorado Springs Utilities. The required size of the secondary cable is 250 kcmil Cu.
 - (f) Service equipment shall be capable of interrupting the available fault current.

(f)(g) For the purpose of protecting customer owned equipment, it is recommended that cable limiters be installed on all customer owned secondary cable and bus equipment. Failure to do so could result in damage to customer owned equipment

and reduced reliability. See Appendix C Table 3 for approved manufacturers and models of cable limiters.

4) Spot (480Y/277):

- (a) A “spot” Network System (480Y/277 volt) consists of two or more transformers in one above ground vault, or other suitable facility, serving an individual Customer with large loads within the boundaries of the network. Typical design is for a multistory office building.
- (b) The maximum diversified load of a spot vault is 2000 kVA. This will consist of a maximum of 3-1000 kVA transformers.
- (c) Colorado Springs Utilities will supply the medium voltage supply cable, modules, transformers and network protectors. A “Spot Network Customer Vault Agreement” form shall be signed. After the form is signed, Colorado Springs Utilities will order the equipment.
- (d) The Customer shall provide the property necessary for an above ground vault or other suitable facility to house network equipment. The Customer is responsible for the purchase and installation of the vault, or other suitable facility, which shall be approved by Colorado Springs Utilities. All above ground level Spot Network Vaults shall conform to Colorado Springs Utilities’ Specification 16-1. This shall be understood to be a minimum requirement. Any deviation from this specification shall be approved in writing by Colorado Springs Utilities.
- (e) After the Spot Network Vault is completed and accepted by Colorado Springs Utilities, the Spot Network Vault shall be designated as Colorado Springs Utilities’ equipment, and Colorado Springs Utilities’ personnel shall approve and directly supervise all work involving Customer penetration into the Colorado Springs Utilities’ equipment (e.g. vault, building). This includes, but is not limited to, all future customer services and vault modifications.
- (f) The Customer is responsible for the purchase and installation of a secondary network bus and switchgear in a location approved by Colorado Springs Utilities. It shall adhere to Colorado Springs Utilities’ material specification 194-8 (Low Voltage Busway for 277/480V Spot Networks). Maintenance of the secondary network bus shall be the responsibility of the Property Owner and/or Customer. The Property Owner and/or Customer shall be qualified to work around energized, electrical equipment, will perform maintenance as specified by the manufacturer of the Customer’s bus and Colorado Springs Utility material specification 194-8 (Low Voltage Busway for 277/480V Spot Networks) and will document the maintenance for Colorado Springs Utilities’ review. For each transformer/network protector unit inside a downtown spot network vault, three-phase AC disconnect switches shall be installed between the network protector and the 480-Volt bus. These AC disconnect switches shall be rated for 1875 A or higher and shall be mounted just inside the vault wall. The 480-Volt bus shall be mounted outside of the spot network vault.
- (g) The Property Owner and/or Customer is responsible for the maintenance of the vault including, but not limited to, structural integrity, exterior condition and unobstructed entry to the vault, including doors and ventilation ducts. The Property

abnormal system conditions. Clearing time is the time between the start of the abnormal condition and the generator ceasing to energize the utility system.

- c) The generator protection and controls must be able to detect an island condition on one or more phases and disconnect all phases of the generator from the Utilities system within two seconds of the formation of an island on any phase.

c) Voltage Control & Flicker:

- 1) The customer-owned generator shall not cause an objectionable voltage flicker at the point of common coupling (PCC). Flicker is considered objectionable when it either causes a modulation of the light level of lamps sufficient to be irritating to humans, or causes equipment misoperation. The type of generation will be considered when determining the frequency of starts and stops.
- 2) The customer-owned generator must have adequate protection and controls to ensure the requirements for frequency, voltage, and phase angle, as described in IEEE 1547, are met prior to paralleling with the Utilities system.
- 3) The generator shall not be a source of excessive harmonic voltage or current distortion. Limits for harmonic distortion (including inductive telephone influence factors) are available in IEEE 519.
- 4) Utilities may require the installation of a power quality monitoring system to permit ongoing assessment of compliance with the aforementioned criteria. The monitoring system shall be installed at the customer's expense.
- 5) If high voltage, low voltage, or objectionable voltage flicker arises due to the operation, frequent tripping, and/or frequent starting and stopping of the generator, the customer shall be required to disconnect its generation equipment from the Utilities system until the problem has been resolved.
- ~~6) Normally, the generated voltage shall follow, not attempt to oppose or regulate, changes in the prevailing voltage level provided by Utilities at the PCC in accordance with IEEE 1547. The customer may be required to coordinate with Utilities Engineering on a prescribed volt/VAR or power factor schedule. All solar or generation projects with an inverter will be assessed for optional advanced inverter settings during the application process. These settings including Volt-VAR setpoints and if required will be communicated to the customer, installer, and other application stakeholders.~~

6)

13.05 Generation with Inverter (PV) Applicable Standards:

- a) Customer-owned generation shall comply with all applicable requirements from the most recent version of:
 - 1) IEEE 1547, "Standard for Interconnecting Distributed Resources with Electric Power Systems"
 - 2) IEEE 1547.1, "Standard Conformance Test Procedures for Equipment Interconnecting Distributed Resources with Electric Power Systems"
 - 3) IEEE 1547.2, "Application Guide for IEEE Std. 1547, IEEE Standard for Interconnecting Distributed Resources with Electric Power Systems"
 - 4) IEEE 1547.3, "Guide for Monitoring, Information Exchange, and Control of Distributed Resources Interconnected with Electric Power Systems"
 - 5) IEEE 519, "Recommended Practice and Requirements for Harmonic Control in Electric Power Systems"

- 4) If the generation site is 500kW or larger, “Breaker Status” and “Load Switch Status” points are to be brought back via the customer’s plant RTU. The customer is to install 52a contacts in their breaker and hardwire into the customer owned RTU. Customer is to send soft points to Utility’s SCADA system. The customer is to install 89a contacts in their load switch and hardwire into the customer owned RTU. Customer is to send soft points to Colorado Springs Utilities’ SCADA system.
- 5) If Colorado Springs Utility fiber network is not installed at the site, a SEL-3061 Cellular Router is required for communications and must be powered from the DC power supply. Note – if using the SEL-3061 router, site must meet Utilities’ cellular network strength requirements

c) Installation Requirements for sites equal to or greater than 500 kW (See Appendix E – Material Specification 193-SPP-SCA for full parts list and design drawings)

This section details the responsibilities of Colorado Springs Utilities and the Customer; first describing the ownership of the installation steps, followed by the financial responsibility of each party in regards to installation.

1) Installation

- a) Colorado Springs Utilities Meter Shop shall install CTs and PTs in the specified enclosure, with a 13-terminal meter socket mounted on the side, and perform wiring in the shop.
- b) If the system is 600 amps the Customer shall prepare the site where the 6’x12’ vault will be installed for the CT/PT enclosure. If the system is 200 amps, customer shall prepare the site where concrete pad will be installed for the PT/CT enclosure.
- c) Customer shall install primary conduit and primary wire with all appropriate connections to the vault site or concrete pad, dig a pit for the vault (if applicable), request and pass inspections, and call Colorado Springs Utilities to schedule the delivery of the 6’x12’ vault or concrete pad.
- d) Colorado Springs Utilities shall install the 6’x12’ vault or concrete pad.
- e) Colorado Springs Utilities shall install the CT/PT padmount enclosure on the 6’x12’ vault or concrete pad after the CTs, PTs, 13-terminal meter socket, and wiring is complete in the shop and after the vault or concrete pad is installed.
- f) Customer shall install the Unistrut structure, per Utilities’ standards, in the field close to the CT/PT enclosure.
- g) Customer shall install weather station and/or other devices to provide the required meteorological data points if applicable (see 13.08b3). This is to tie into the customer’s RTU.
- h) Colorado Springs Utilities or their contractor shall pre-build the SCADA enclosure by installing ~~an RTU, power supply, remote antenna and~~ radio, SEL-735 meter and test switch prior to installing enclosure in field.
- i) Colorado Springs Utilities-Customer shall coordinate with Colorado Springs Utilities to pick up SCADA cabinet and install the SCADA cabinet on customer installed Unistrut structure in the field. shall install the SCADA enclosure on customer installed Unistrut structure in the field.
- j) Customer shall install a 2” riser with a 2” LB conduit body and a weather head for the radio antenna. (See Appendix E – Material Specification 193-SPP-SCA)
- k) Colorado Springs Utilities will install a radio antenna, cellular antenna and all associated wiring in the enclosure.
- l) Customer shall install conduit from the 13 terminal meter socket, mounted on the CT/PT enclosure, to the SCADA enclosure, and from the single phase 120/240 V

transformer to the SCADA enclosure. All conduit must be rigid 1.5 inch (minimum) with a maximum of three 90 degree bends (a total of 270 degrees)..

- ~~k)m~~ Customer to pull secondary 10 gauge wire from single phase 120/240 V transformer to SCADA enclosure to provide 120V to the power distribution DIN rail. Customer to terminate the 10 gauge wire inside single phase 120/240V transformer. Colorado Springs Utilities to terminate inside SCADA enclosure.
- ~~l)n~~ Colorado Springs Utilities shall pull control wires from the 13-terminal meter socket test switch to the test switch inside the SCADA enclosure and terminate at both ends. The SEL-735 meter will be supplied by 120V AC power rail in the SCADA enclosure.
- ~~m)o~~ Customer shall install conduit and wiring multimode fiber from the customer's RTU electric controls to Utilities' SCADA enclosure.
- ~~n)p~~ Colorado Springs Utilities shall tie in wiring multimode fiber from customer's RTU electric controls to Utilities' radio Utilities' media convertor transceiver in the SCADA enclosure. Utilities shall perform all other wiring for telemetry.
- ~~o)q~~ Colorado Springs Utilities Customer shall install a prep concrete pad site, install pad and 120/240V single-phase padmount transformer to supply 120V to the SCADA cabinet and meter on the same circuit. Transformer is to be fed from the same primary circuit that the SCADA cabinet and meter are being fed from.

2) The customer is responsible for paying and providing:

- a) Unistrut structure and 2" riser for radio antenna.
- b) Weather station and/or other devices for meteorological data points (as required)
- c) 52a and 89a contacts to provide breaker and load switch status points
- d) Conduit and ~~wiring multimode fiber~~ from the customer's RTU controls to Utilities' SCADA enclosure
- e) Conduit and wiring from single-phase 120/240 V transformer to the SCADA enclosure
- f) Pit for 6'x12' vault, ~~or~~ preparing the site for concrete pad, installing primary conduit and primary wire with all appropriate connections, scheduling and passing inspections, and scheduling the vault ~~installation or concrete pad installation~~ with Colorado Springs Utilities
- g) Conduit from 13-terminal meter socket, mounted on CT/PT enclosure, to SCADA enclosure
- h) A 120/240V single-phase transformer pad meeting Utilities' and regional building department's requirements, such as including proper compaction and correct final grade.
- h)i) A 120/240 V single-phase padmount transformer and all primary work involved.

3) The following items will be provided by the Utility, and paid for by the Customer:

- a) All items required for the SCADA and metering enclosure (See Appendix E – Material Specification 193-SPP-SCA for full list and part specifications) including
 - ~~(1) CT/PT enclosure with 13 terminal meter socket~~
 - ~~(2) SCADA enclosure~~
 - ~~(3) RTU~~
 - ~~(4) AC/DC Power supply~~
 - ~~(5) Remote antenna and radio~~
 - ~~(6) SEL-735 meter~~
 - ~~(7) SEL-3061 cellular router~~
 - ~~(8) Test switches~~

~~(9) CTs and PTs~~

~~(10) Wiring from the 13 terminal meter socket, mounted on CT/PT enclosure, to the SCADA enclosure for current and voltage potentials~~

~~(11) 6'x12' vault~~

b) Labor costs incurred by Utilities due to the Utilities owned tasks listed above, including enclosure assembly and wiring, inspections, vault or concrete pad and enclosure installations, and other wiring

~~e) 120/240V single phase padmount transformer for the purpose of powering the SCADA cabinet and meter on the same circuit.~~

d) Electric Design Information to be provided to Colorado Springs Utilities (to be provided one time and subsequently if there is a change)

1) Contact information - 24x7 contact information

- a) Generation Owner
- b) Generation operator

2) Geographical Data

- a) Coordinates of the corners of the generation site including, but not limited to, the northwestern, northeastern, southwestern, and southeastern locations, in order to properly identify the exact footprint and area of the site
- b) One set of latitude and longitude coordinates for generation site mid-point
 - (1) Latitude – Latitude of the resource location, including the mid-point and four corners of the generation site, submitted as degrees in decimal form rounded to four digits
 - (2) Longitude – Longitude of the resource location, including the mid-point and four corners of the generation site, submitted as degrees in decimal form rounded to four digits
- c) One set of latitude and longitude coordinates for meteorological collection device station (if required per generation type)
 - (1) Latitude – Latitude of the meteorological station submitted as degrees in decimal form rounded to four digits
 - (2) Longitude – Longitude of the meteorological station submitted as degrees in decimal form rounded to four digits

3) General Generation Resource Data (for all generation types)

- a) Manufacturer - Manufacturer of the generation technology.
- b) Model - Model of the generation devices. Provide any prefixes and suffixes if available

4) Solar Powered Generation Resource Data (for solar generation sites only)

- a) Generation Devices – The number of panels, mirrors, or thermal cells at the site
- b) Capacity – The nameplate capacity of each unit; both AC and DC capacity
- c) Degradation Factor – Yearly degradation factor percentage
- d) Temperature Coefficient – Percent over degrees Celsius
- e) Tilt – Altitude angle or angle range for units
- f) Azimuth Angle – Azimuth angle or angle range for units (alignment due south)
- g) Height – Elevation of panels above surface level
- h) Inverter Technology – Centralized inverters, string inverters, micro inverters and/or maximum power point trackers.
- i) Tracking data (only if a tracking system is equipped).
 - (1) Type – Single or dual-axis tracking
 - (2) Manufacturer – Manufacturer of the tracker

TABLE OF CONTENTS

Appendix B Utilities Addressing Plan, Utilities Design CAD File and Easements Policies and Procedures

Chapter Number	Title	Page Number
B.1.0	Introduction.....	B-2
B.2.0	Utilities Addressing Plan.....	B-2
B.2.1	Conditions Calling for a Utilities Addressing Plan.....	B-2
B.2.2	Purpose of the Utilities Addressing Plan.....	B-3
B.2.3	Utilities Addressing Plan Submittal.....	B-3
B.2.4	UAP Frequently Asked Questions.....	B-3
B.3.0	Utilities Design CAD File.....	B-3
B.3.1	Conditions Calling for a Utilities Design CAD File.....	B-4
B.3.2	Purpose of the Utilities Design CAD File.....	B-4
B.3.3	Utilities Design CAD File Submittal.....	B-4
B.3.4	UDCF Frequently Asked Questions.....	B-5
B.4.0	Easements.....	B-6
B.4.1	Conditions Calling for an Easement.....	B-6
B.4.2	Required Easement Elements.....	B-6
B.4.3	Easement Submittal Process.....	B-67
B.4.4	Easement Frequently Asked Questions.....	B-7
FORM 1	UAP Checklist.....	B-8
TABLE A	UDCF Feature List.....	B-9

UTILITIES ADDRESSING PLAN,
UTILITIES DESIGN CAD FILE AND EASEMENTS
Policies and Procedures Guide

B.1.0 INTRODUCTION

Interaction with Colorado Springs Utilities (UTILITIES) on any land development project requires supporting documentation. This information is unique to a given type of service (i.e. electric, gas, water or wastewater). There are two types of support data that are universal to all service extensions: the Utilities Addressing Plan (UAP) and the Utilities Design CAD File (UDCF). Depending upon the nature and timing of your project you may need to submit a UAP and/or a UDCF as part of the flow of information to UTILITIES in support of the design or review of your proposed utility infrastructure. It is best to be aware of these two items as well as potential easement requirements in advance of your first contact with UTILITIES regarding a given project. The following Sections describe each item in detail.

B.2.0 UTILITIES ADDRESSING PLAN

The UAP is a submittal that must be made, under certain circumstances, to UTILITIES prior to initiating a request for utility design review or service extension from SU. The content of the UAP is similar to that of a subdivision plat (see FORM 1 for the UAP checklist). In fact, a copy of the subdivision plat prepared per the City of Colorado Springs Code pertaining to Subdivision Platting will suffice as a UAP submittal. Advanced Geomatics (ADG) uses the UAP to obtain addressing from the Regional Building Department's (RBD) enumerator's office for the lots in the project. ADG converts lot geometry for the proposed project to the cadastral layers of the ADG database and create address pointers for the lots. The ADG cadastre, address data and SU's Customer ~~Care and~~ Billing (~~CCnBC2M~~) system are synchronized using this information.

B.2.1 CONDITIONS CALLING FOR A UTILITIES ADDRESSING PLAN

A Utilities Addressing Plan is required to be submitted to UTILITIES anytime an application for the design of extensions of electric, gas, water or wastewater mains and/or service lines is made and any of the following conditions apply:

- The request for service applies to a parcel of land that does not have a recorded final subdivision plat and assigned addressing in place as of the date of the request.
- The request for service applies to a parcel of land which may have an existing recorded plat in place, but the existing parcel geometry will be modified as part of a land development process and the replat is not yet of record.
- The request for service applies to a parcel of land for which an approved UAP exists, but changes have been made (or are proposed) to the geometry of the development which substantially affects the lot or street configuration of the development.
- The proposed development activity will in any way change approved addressing on the site.

B.2.2 PURPOSE OF THE UTILITIES ADDRESSING PLAN

The UAP serves two critical purposes in the land development process. Information provided on the UAP allows ADG to create preliminary lot and street geometry in the UTILITIES Geographic Information Systems database. Approved addressing is then entered into the addressing database which in turn is tied to the UTILITIES ~~C2MCCnB~~-system. With this in mind, consider the UAP as a “Preliminary” version of the final plat. The data elements to be shown are nearly identical to a final plat and in fact, an unrecorded copy of the final plat of the project is an acceptable UAP.

B.2.3 UTILITIES ADDRESSING PLAN SUBMITTAL

The UAP can be submitted in either hardcopy format or electronically. The UAP must be submitted at least *five (5) working days prior* to the need for SU’s action on a request for service. Requests for service may be submitted concurrently with the UAP but will not be acted upon until after the UAP has been processed.

A revised UAP must be submitted whenever boundary, right-of-way, lot or easement lines or dimensions are revised, or if addresses or street names are changed.

Digital submittal

Digital UAP submittals are the preferred method. Digital submittals may be performed online using the Digital Data Services web link (<https://www.csu.org/Pages/GISMapping.aspx>). When a submittal is made online, a receipt is emailed to the user. This receipt must accompany the request for utility service, as evidence that the UAP has been processed if the UAP is required (see above section for conditions requirement). A digital submission shall consist of an AutoCAD drawing (.dwg) file with a layout for each sheet (where there are multiple sheets to the plan) of the proposed project including all necessary model and paper space elements to enable ADG staff to print hard copies. For information or assistance in performing online UAP submittal, contact ADG staff at C_ADGSupport@csu.org or (719) 668-~~8340~~ 7920 or 668-8779.

B.2.4 UAP FREQUENTLY ASKED QUESTIONS

Do I need to have accurate and correct dimensioning for lots and streets centerlines on the UAP?

Although a preliminary version of the plat is acceptable for the UAP, fictitious, incomplete or erroneous plat geometry is not. UTILITIES require sufficient information on the UAP to be able to run coordinate geometry on the boundaries, the rights of way, tracts and each individual lot. Missing or erroneous data will only delay the UAP processing because ADG staff will refer the errors back to the submitter for correction before completing the UAP.

B.3.0 UTILITIES DESIGN CAD FILE

The Utilities Design CAD File (UDCF) is an AutoCAD (.dwg format) drawing file which contains specific point, line and text features related to the design and analysis of new utility lines in proposed land developments and public works projects. Defining the content and structure of the CAD data to be received allows ADG to position the UDCF file when necessary, enabling UTILITIES system designers to provide a more efficient design process for each land development customer. The primary use of the UDCF is to meet the requirements of the water, gas and electric system designers. It will contain electronic feature data (see TABLE A for a list of recommended features) needed to do CAD based

B.4.0 EASEMENTS

Development activity often requires an extension of UTILITIES’s infrastructure, which in turn may lead to the need for an easement or executive agreement. Across City property (not a Public Right – Of – Way), an Executive Agreement is required. On private property, Easements are required when infrastructure is placed outside of a public right-of-way. Easements are typically granted either by a Subdivision Plat or by a Permanent Easement Agreement. Easements granted by Subdivision Plat are governed by the City of Colorado Springs Code pertaining to Subdivisions, as modified by the Terms & Conditions recorded at Reception Number 212112548. Easements obtained through a Permanent Easement Agreement are controlled by the Utilities’ Standard Procedures for Easement Acquisition and Reference (SPEAR) process. The Spear Easements process now goes through the Construction & Development Hub. At this location users can select the “Development Process” link to see Utilities’ Development process and all the phases within. Under the Construction Phase, the user can select Easement Submittal link that will provide access to the Utilities Easement Procedures along with Easement Preparation Checklists. The user will also find a series of Permanent Easement Templates for different types of easements. This information will guide the user through the easement Submittal process where the required checklist can be submitted to Development Services for review.

***** Please note, the Land Management team (Jessica Davis) should be used to help acquire any new easements or for changes to existing easements. Please call 688-7581 for help. *****

B.4.1 CONDITIONS CALLING FOR AN EASEMENT

If utilities are installed outside of a public right-of-way or existing UTILITIES utility easement, then a UTILITIES utility easement must be granted. The need for an easement may be triggered by a neighboring development or even a UTILITIES initiated project that requires the installation of utilities across the property and not falling within a dedicated right-of-way or existing easement. These circumstances would require the recording of a Permanent Easement Agreement

B.4.2 REQUIRED EASEMENT ELEMENTS

SU’s Permanent Easement Agreement has a standard set of Terms & Conditions, and three (3) exhibits. Exhibit A is a description of the parcel burdened by the easement. This description could consist of a reference to a platted lot, a metes and bounds description or an existing reception number / book and page. Exhibit B is a description of the easement area. Exhibit C is a graphical representation of the easement area described in Exhibit B. UTILITIES require that Exhibit B be prepared, signed and sealed by a Colorado Professional Land Surveyor.

UTILITIES staff reviews the easement document for conformance to the design specification, and generally accepted surveying standard of care. During the review process comments may be referred back the Land Developer for review or revision. Upon acceptance by UTILITIES the easement is recorded at the Clerk & Records Office, and a recorded copy provided to the Land Developer.

B.4.3 EASEMENT SUBMITTAL PROCESS

Most easements dedicated to UTILITIES are initiated by the developer of the property in order to receive utility service. The need for a utility easement is identified during the Development Plan review process. The submittal process is explained on the UTILITIES website at the link given in 4.0 above.

Some of the key aspects are:

1. Always download the latest easement agreement forms from the UTILITIES website.
2. A licensed professional land surveyor must sign and certify that the exhibits prepared under their direct supervision, are accurate and correct to the best of their knowledge. [Please see Advanced Geomatics if any questions arise about this item.](#)
3. All owners and any Deed of Trust holders must sign the easement and ensure that their signatures are notarized.

B.4.4 EASEMENT FREQUENTLY ASKED QUESTIONS

How wide of an easement do I need to grant?

In general, a water or wastewater main requires a 30' easement width and a multi-utility easement is required to be 50' wide. Sometimes a wider easement is required based on characteristics of the line such as size, pressure, slope or depth of installation. Contact Development Services or refer to the appropriate standards to understand what the easement width might be for your utility installation project.

Can the utility be installed within an existing access easement?

Not typically. [Not all existing easements have full rights for utility infrastructure.](#) The Terms and Conditions of the actual easement agreement would need to be reviewed for language permitting the installation, maintenance and access to the infrastructure.

I need to dedicate an easement across multiple lots. What is the best way to do this?

If the multiple lots are owned by the same legal entity, the easement could be granted on a single easement. If the easement would include multiple owners, it is required that the easement be split into multiple sections so that each easement is granted by a single legal entity. The exception to this is for property held jointly for which a standard easement agreement was prepared.

What rights do I, as the owner, retain within the easement area?

Springs Utilities Permanent Easement Agreement is very specific on what rights are granted to the City of Colorado Springs and what rights are retained by the property owner. Please refer to the easement agreement, contact Development Services or seek legal counsel for answers to more specific questions.

Table A – UDCF Feature List

***** Following this Feature List Guide, helps to get CAD files approved and ingested as quickly as possible. CSU staff thanks you for using and following this information! *****

Recommended Feature Data	Residential	All Others	Recommended CAD Layer Name
Lot Lines	X	X	xx-lots-lin
Project Exterior Boundary Lines	X	X	xx-sub-bdy
Street Lines	X	X	xx-row-street
Easements	X	X	see list below
			xx-esmt-access
			xx-esmt-avig
			xx-esmt-drain
			xx-esmt-pub
			xx-esmt-scenic
			xx-esmt-trail
			xx-esmt-util
			xx-easmt-util-gas
			xx-easmt-util-elec
			xx-easmt-util-water
			xx-easmt-util-ww
			xx-esmt-util drain
			xx-esmt-util pub
			xx-esmt-util-misc
Building Footprints		X	xx-building-ftpnt
Water Lines	X	X	xx-water-line
Water Services	X	X	xx-water-serv
Water Valves		X	xx-water-valve
Fire Hydrants	X	X	xx-water-fh
Gas main lines (proposed)	X	X	pp-gas-line
Gas service lines (proposed)	X	X	pp-gas-stub
Electric lines (proposed)	X	X	pp-elec-line-ug (underground)
			pp-elec-line-ug (overhead)
Transformer Location		X	pp-elec-tr_pad
Elec sevice attachment points (proposed)		X	pp-elec-serv_att_pt
Secondary Electric		X	xx-electric-line-ug (overhead)
			xx-electric-line-ug (underground)
Sanitary Sewer Lines	X	X	xx-ww-line
Sanitary Sewer Manholes	X	X	xx-ww-mh
Sanitary Sewer Services	X	X	xx-ww-serv
Underdrains	X	X	xx-drain-udline
Storm Sewer Lines	X	X	xx-drain-line
Storm Sewer Inlets (Catch Basins)	X	X	xx-drain-catch
Curb Lines	X	X	xx-curb-back
			xx-curb-fl
			xx-curb-lip
Hard Surfaces (Paved Areas)		X	see list below
			xx-alley-pvd
			xx-drain-chan-1nd
			xx-drain-cross
			xx-drive-pvd

<p>Meter Socket, 4 Terminal, 320A, Lever Bypass (Residential or Commercial, 1-Phase, underground, self-contained meters)</p>	<ul style="list-style-type: none"> • Single Phase, 3 Wire, 120/240V 	<p>See Chapter 5, 5.05 “Self-Contained Meter Sockets”, Appendix E - Specification 102-1, and Appendix F – Standard 14-11 “Meter Socket Wiring Schematics” for meter socket requirements.</p>
<p>Meter Socket, 7 Terminal, 200A, Lever Bypass (Commercial, 3-Phase, only for self-contained meters)</p>	<ul style="list-style-type: none"> • Three Phase, 4 Wire-Wye, 120/208V • Three Phase, 4 Wire-Wye, 277/480V • Three Phase, 4 Wire-Delta, 120/240V 	<p>Milbank Manufacturing Co:U4701-RRL</p> <p>Cutler Hammer: UTE7213BCH</p> <p>Siemens/Landis & Gyr: 40407-025</p> <p>Suggested manufacturers listed above or other equivalent. See Chapter 5, “5.05 Self-Contained Meter Sockets”, Appendix E – Specification 102-600-130, and Appendix F – Standard 14-11 “Meter Socket Wiring Schematics” for meter socket requirements.</p>
<p>Meter Socket, 13 Terminal, 20A, Pre-wired Test Switches, Instrument Transformer Rated (Commercial, 3-Phase, for CT meter)</p>	<ul style="list-style-type: none"> • Three Phase, 4 Wire-Wye, 120/208V • Three Phase, 4 Wire-Wye, 277/480V • Three Phase, 4 Wire-Delta, 120/240V 	<p>Milbank Manufacturing Co:*</p> <p>UC3913-RL-WC-11</p> <p>Siemens 9837-0701*</p> <p>Tesco:* 9070822-CL</p> <p>See Appendix E for Material Specification 102-600-077.</p>
<p>Meter Socket, 8 Terminal, 20A, Pre-wired Test Switches, Instrument Transformer Rated (Commercial, 3-Phase & 1-Phase, for CT meter)</p>	<ul style="list-style-type: none"> • Single Phase, 3 Wire-Wye, 120/208V • Single Phase, 3 Wire-Wye, 120/240V • Three Phase, 3 Wire-Delta, 120/240V • Single Phase, 4 Wire-Delta, 120/240V 	<p>Milbank Manufacturing Co:*</p> <p>UC4415-RL-WC-21</p> <p>Tesco:* 9070815-CL</p> <p>See Appendix E for Material Specification 102-600-070.</p>
<p>Streetlight J-Box 13”x24”x18”</p>	<p>Streetlight feeder connection J-Box</p>	<p>Armorcast Products: A6001946TAPCX18 STREETLIGHT</p> <p>Oldcastle Enclosure Solutions: 13241409</p> <p>Hubbell: A54132418A041</p>

<u>FUSE, CABLE LIMITER,</u> <u>250 KCMIL, 600 V</u>	<u>250 KCMIL Cable</u> <u>Limiters</u>	<u>Eaton:*</u> <u>Bussman KFT</u>
--	---	--------------------------------------

* Approved manufacturer as listed or approved equal. Approval must be in writing by Colorado Springs Utilities Engineering Standards.

**DRAWING 12A - POST TYPE INSTRUMENT TRANSFORMER (CT & VT)
METER INSTALLATION (FROM A CT CABINET)**

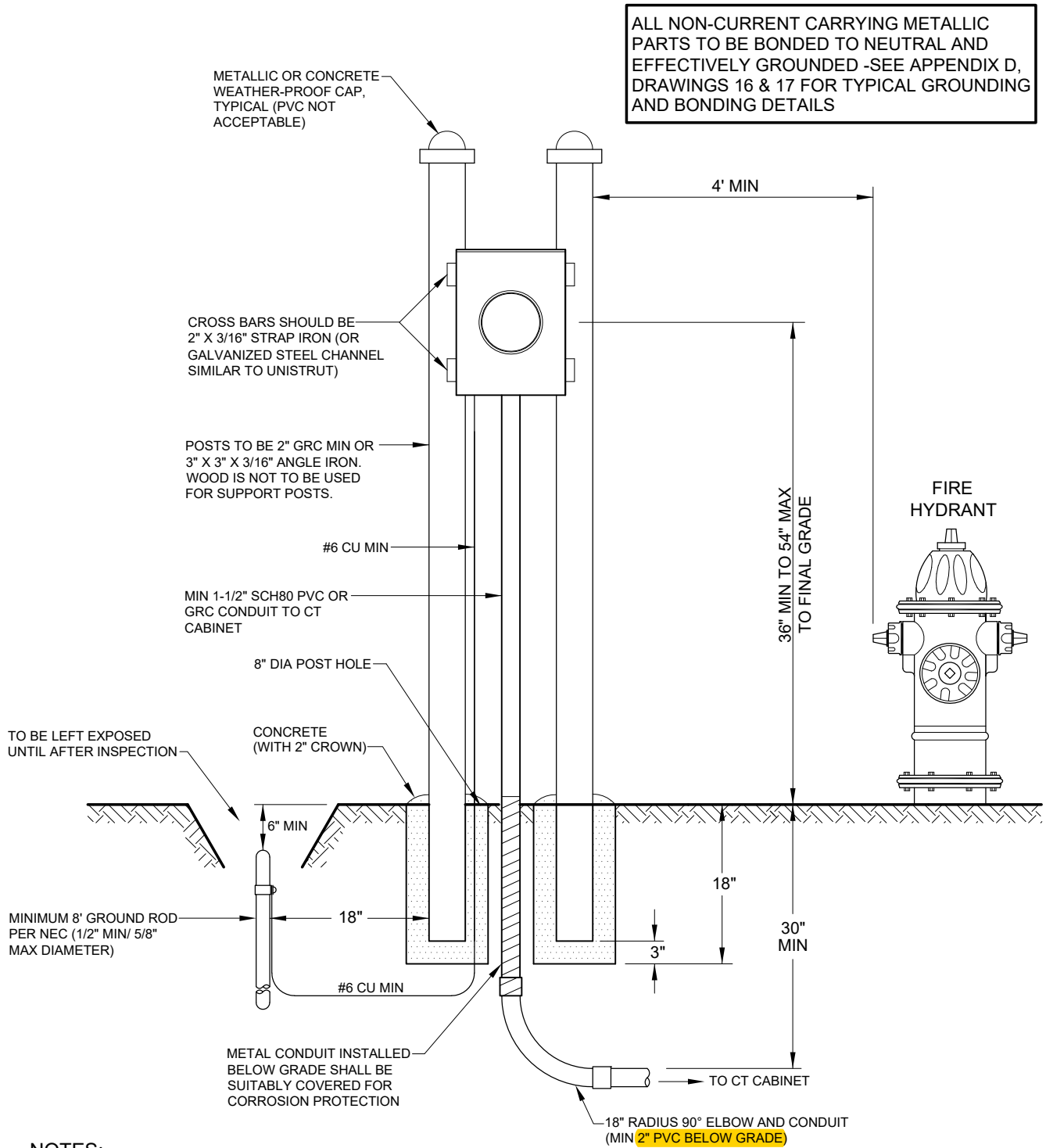

ALL NON-CURRENT CARRYING METALLIC PARTS TO BE BONDED TO NEUTRAL AND EFFECTIVELY GROUNDED -SEE APPENDIX D, DRAWINGS 16 & 17 FOR TYPICAL GROUNDING AND BONDING DETAILS

NOTES:

1. Meter to be mounted with a maximum distance (total length of conduit run including all bends) of 20' from instrument transformers (CTs & VTs), refer to paragraph 5.04e for instrument transformer conduit installation.
2. Both posts must be effectively grounded.
3. Refer to trench information, 10.1f (commercial).
4. Connect #6 copper conductor from ground rod to ground terminal inside meter enclosure; this ground is in addition to that which may be required by the Regional Building Department.
5. Provide pull line for instrument transformer (CT & VT) wire.
6. For 277/480 volt services, a VT ("VT Pack") is required.

DRAWING 12B - POST TYPE INSTRUMENT TRANSFORMER (CT & VT) METER INSTALLATION (FROM CT'S IN A TRANSFORMER)

ALL NON-CURRENT CARRYING METALLIC PARTS TO BE BONDED TO NEUTRAL AND EFFECTIVELY GROUNDED -SEE APPENDIX D, DRAWINGS 16 & 17 FOR TYPICAL GROUNDING AND BONDING DETAILS

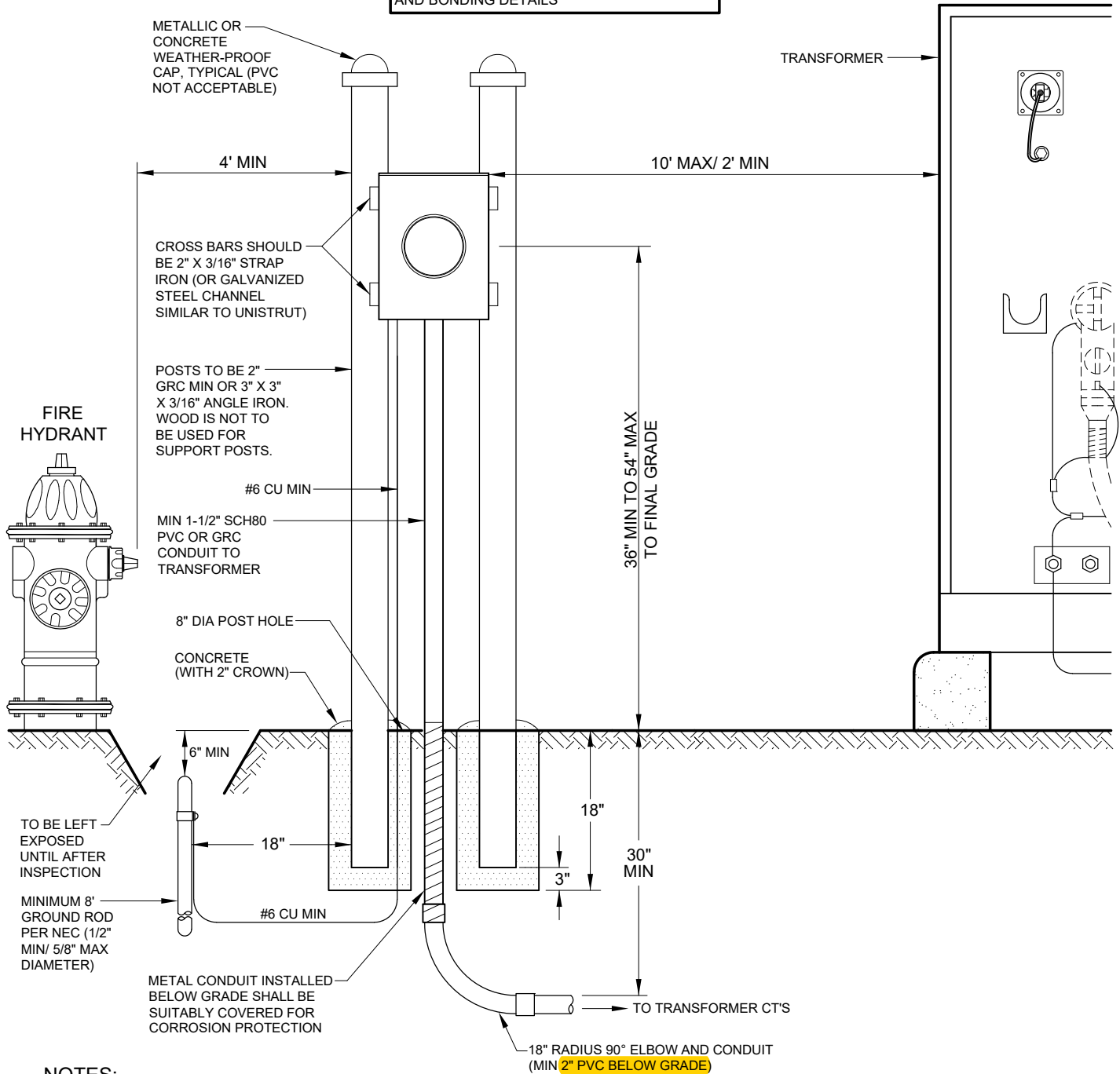

NOTES:

1. Meter Socket must be mounted along side or behind the transformer on a pedestal or post (unistrut or other), at least 2' but not to exceed 10' as shown. Socket location cannot be in front of the transformer or in a location that interferes with truck access. See Appendix F, 18-302 page 2 for padmount equipment clearances for working space. See Chapter 5, paragraph 5.04e for instrument transformer conduit installation.
2. Both posts must be effectively grounded.
3. Refer to trench information, 10.1f (commercial).
4. Connect #6 copper conductor from ground rod to ground terminal inside meter enclosure; this ground is in addition to that which may be required by the Regional Building Department.
5. Provide pull line for instrument transformer (CT & VT) wire.
6. For 277/480 volt services, a VT ("VT Pack") is required.

DRAWING 13 - INSTRUMENT TRANSFORMER (CT & VT) METERING INSTALLATION

ALL NON-CURRENT CARRYING METALLIC PARTS TO BE BONDED TO NEUTRAL AND EFFECTIVELY GROUNDED -SEE APPENDIX D, DRAWINGS 16 & 17 FOR TYPICAL GROUNDING AND BONDING DETAILS

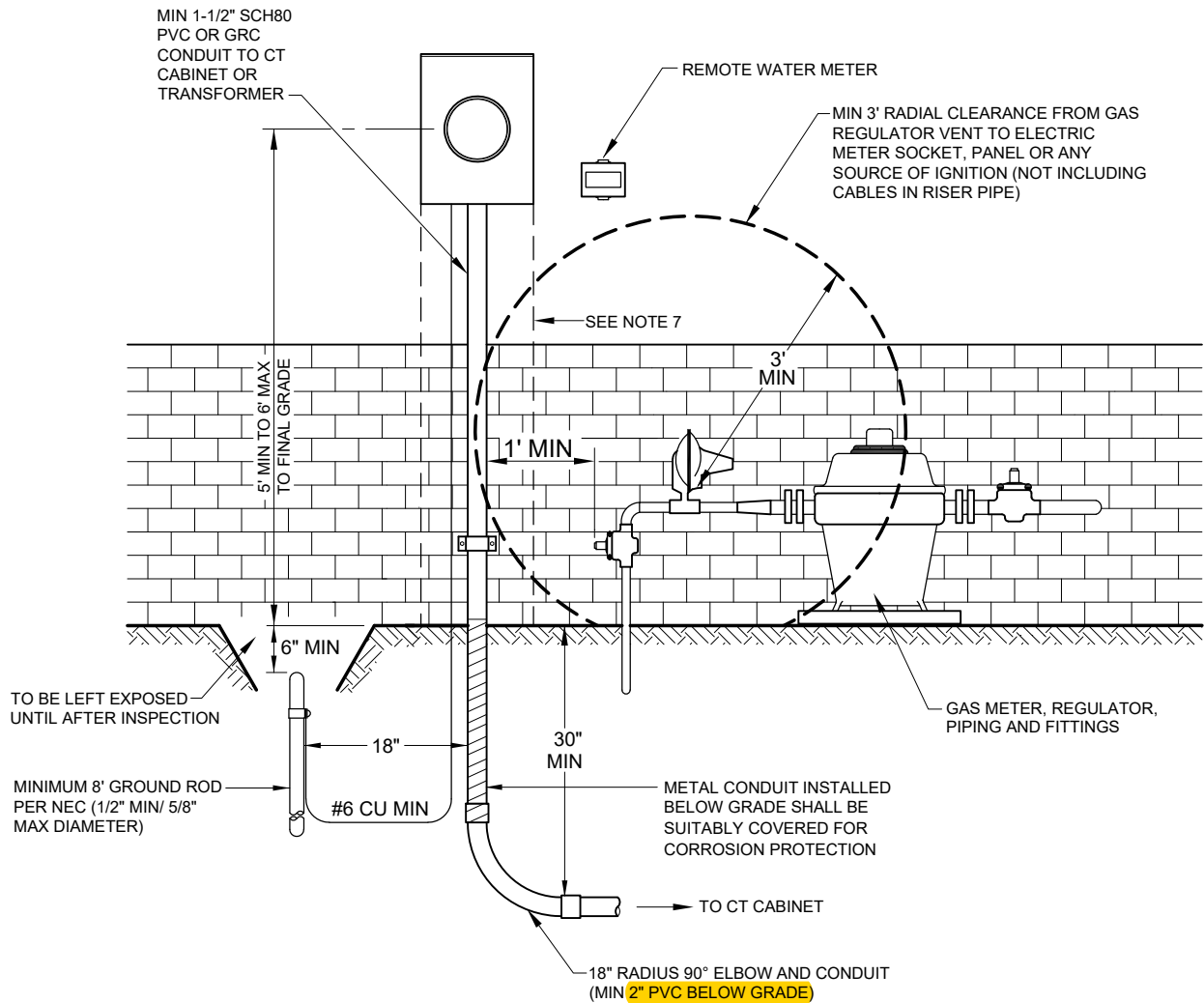

NOTES:

1. Meter to be mounted with a maximum distance (total length of conduit run including all bends) of 20' from instrument transformers (CTs & VTs), refer to paragraph 5.04e for instrument transformer conduit installation.
2. Conduit clamp must be above ground.
3. Refer to trench information, 10.1f (commercial).
4. Connect #6 copper conductor from ground rod to ground terminal inside meter enclosure; this ground rod is in addition to that which may be required by the Regional Building Department.
5. Provide pull line for instrument transformer (CT & VT) wire.
For 277/480 volt services, a VT ("VT Pack") is required.
6. All above ground gas piping to be installed outside of meter socket (30" minimum) clear working space.

DRAWING 14 - CT CABINET INSTALLATION

ALL NON-CURRENT CARRYING METALLIC PARTS TO BE BONDED TO NEUTRAL AND EFFECTIVELY GROUNDED -SEE APPENDIX D, DRAWINGS 16 & 17 FOR TYPICAL GROUNDING AND BONDING DETAILS

NOTE:
PHYSICAL HEIGHT OF CT'S FROM FINISHED GRADE SHALL BE CENTERED BETWEEN 48" TO 72"

NOTE:
MINIMUM CT CABINET SIZE
FOR 1Ø = 18"X 24"X 10"
AND 3Ø = 30"X 30"X 10"

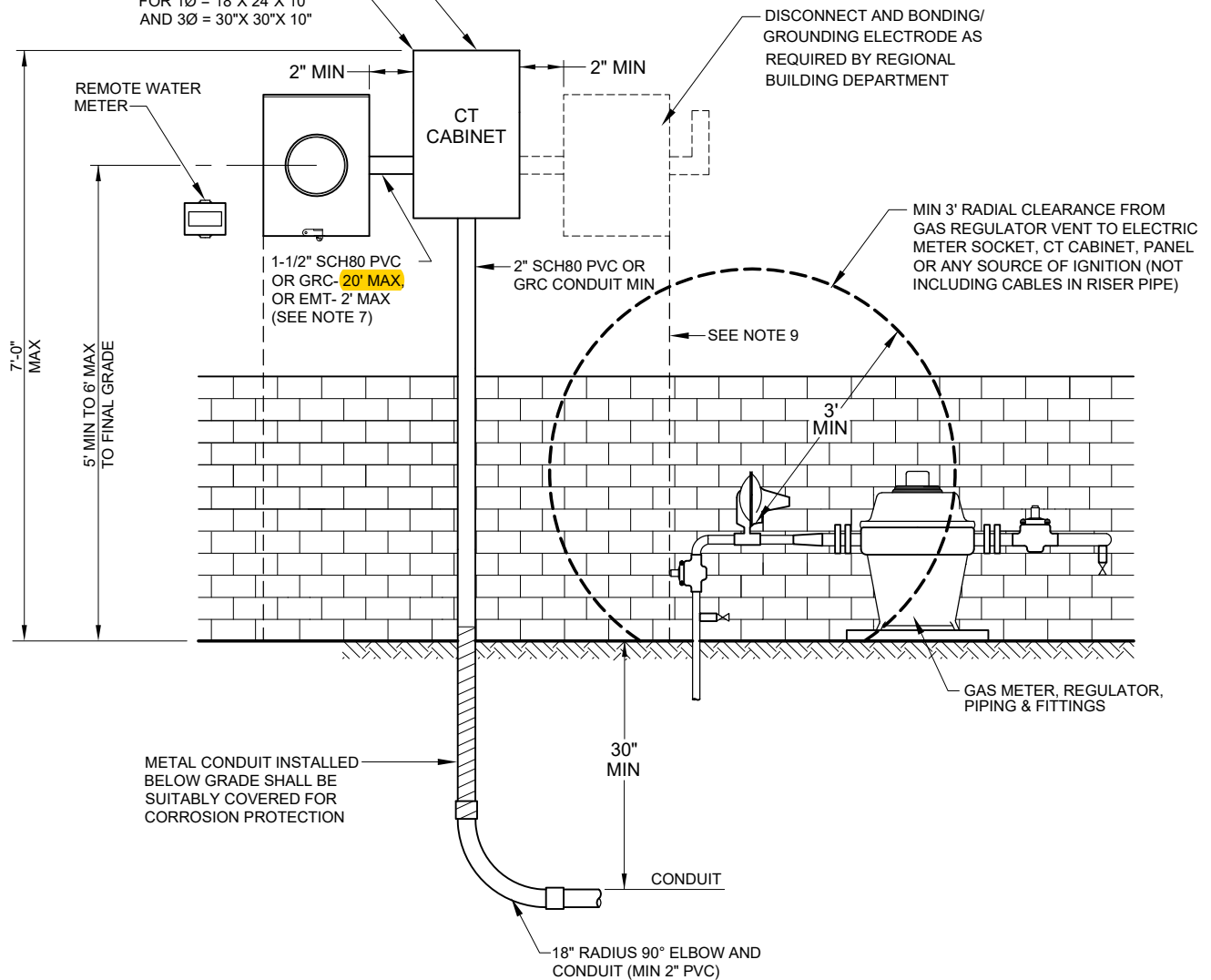

NOTES:

1. CT cabinet to be sealable by Colorado Springs Utilities.
2. See Section 5.12 regarding equipment ahead of the meter.
3. Installation to conform with Chapter 10 Commercial/Industrial Development.
4. Conduit clamp must be above ground.
5. GRC conduit shall be suitably covered below grade for corrosion protection.
6. Refer to trench information, 7.02a (residential) or 10.1f (commercial).
7. Install conduit towards front of CT cabinet to avoid CT secondary wiring behind service entrance conductors.
8. For 277/480 volt services, a VT ("VT Pack") is required to be installed inside the CT cabinet.
9. All above ground gas piping to be installed outside of each meter socket (30" minimum) clear working space.

DRAWING 15 - COMBINATION METERING INSTALLATION

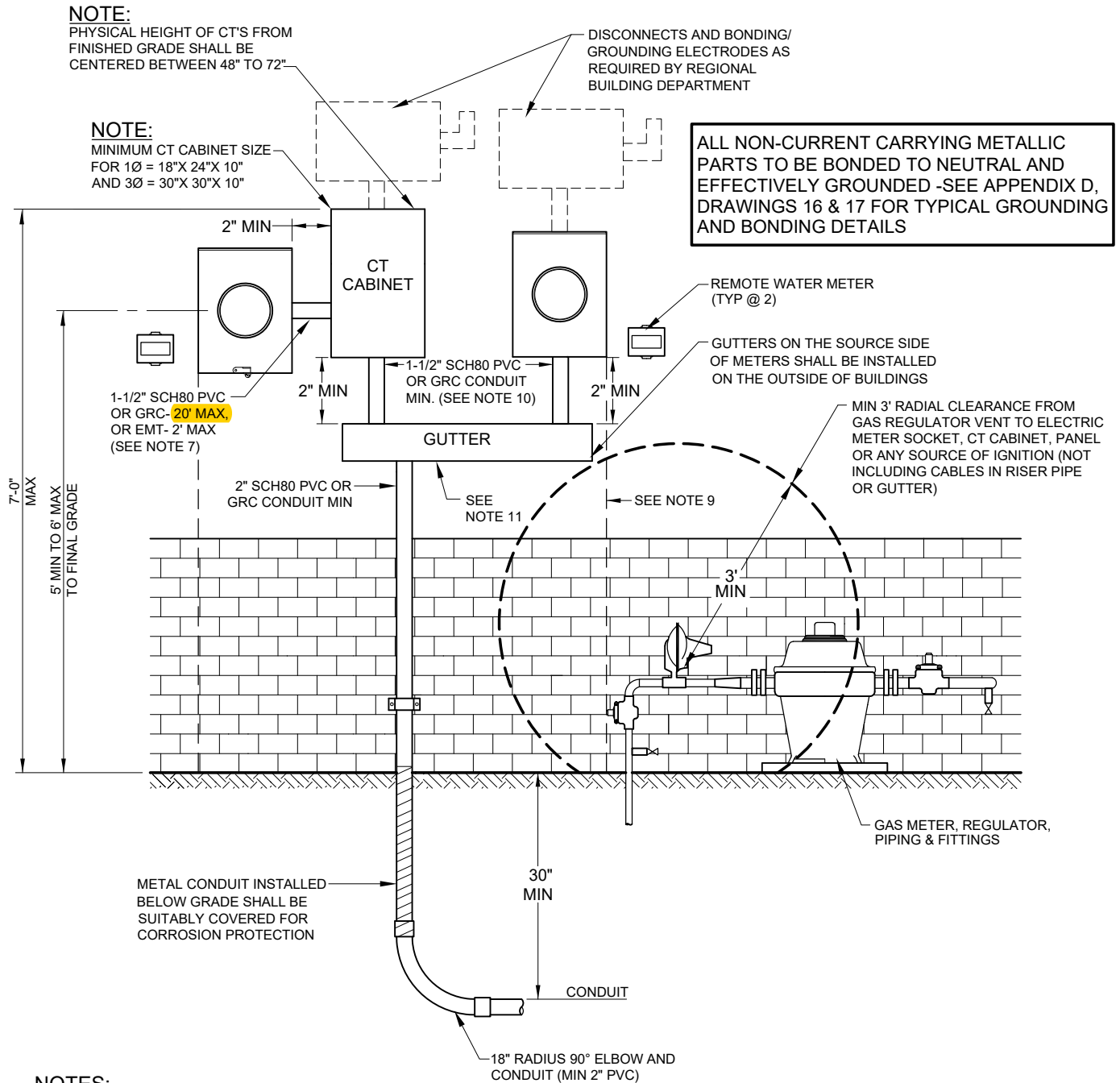

NOTES:

1. CT cabinet and gutter to be sealable by Colorado Springs Utilities.
2. See Section 5.12 regarding equipment ahead of the meter.
3. Installation to conform with Chapter 10 Commercial/Industrial Development.
4. Conduit clamp must be above ground.
5. GRC conduit shall be suitably covered below grade for corrosion protection.
6. Refer to trench information, 10.1f (commercial).
7. Install conduit towards front of CT cabinet to avoid instrument transformer (CT & VT) secondary wiring behind entrance conductors.
8. For 277/480 volt services, a VT ("VT Pack") is required to be installed inside the CT cabinet.
9. All above ground gas piping to be installed outside of each meter socket 30" minimum clear working space.
10. See 5.12 for requirements for sealing equipment ahead of the meter.
11. Avoid passing one customer's service entrance conductors through another customer's equipment.

DRAWING 19 - OUTDOOR COMMERCIAL SWITCHGEAR METERING OPTION

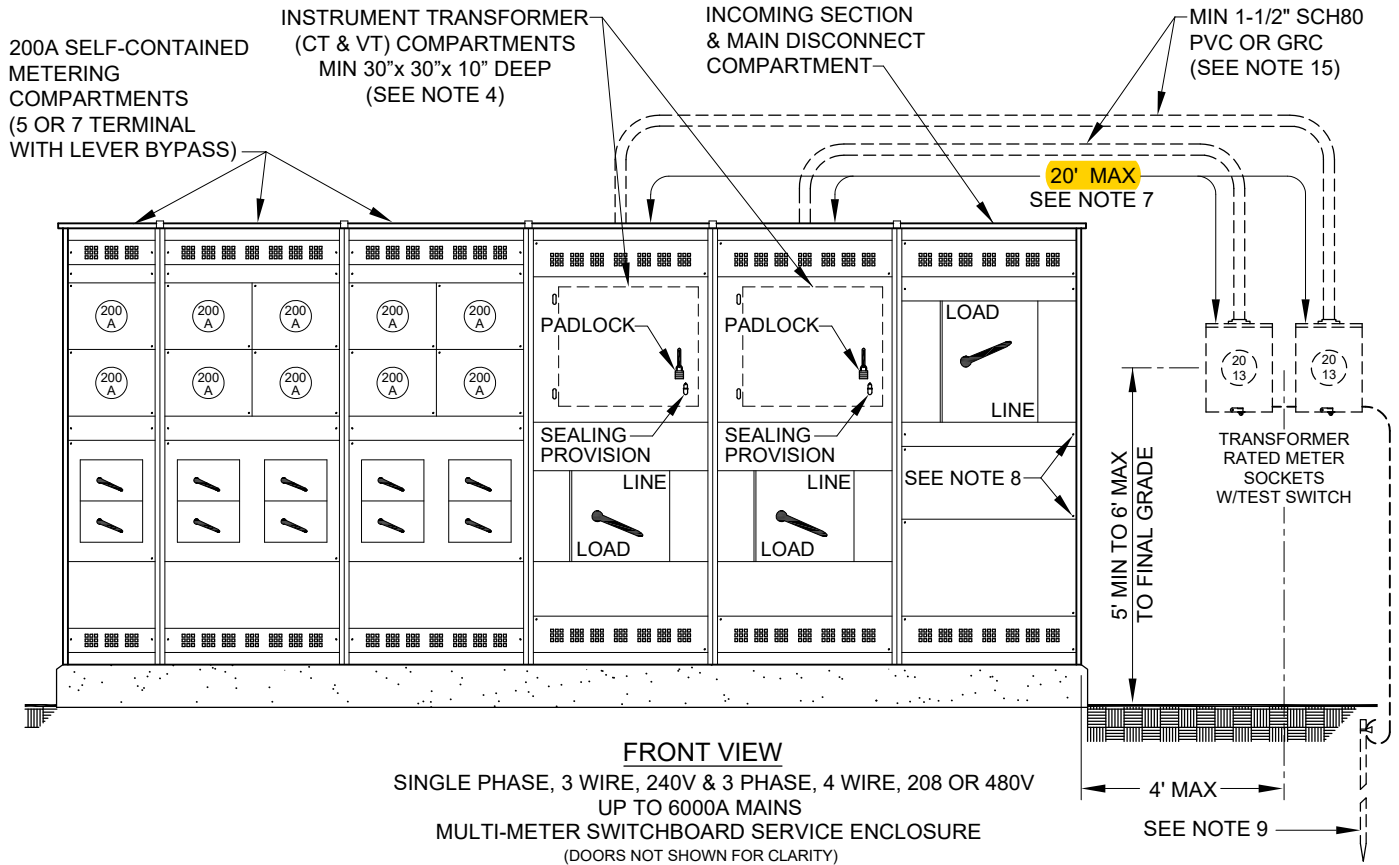

NOTES:

1. Metering switchgear (deadfront distribution switchboards rated 600 volts or less) is an option to be provided, installed and maintained by customer.
2. Metering switchgear shall consist of pad-mounted deadfront switchboards rated 6000 amperes or less, 600 volts or less, the enclosure sections shall contain circuit breakers (molded case and low-voltage power), fusible or non-fusible switches, mounting provision for instrument transformers (CTs & VTs), and metering or control equipment. Metering switchgear shall be constructed of galvanized steel or aluminum, and meet all applicable NEMA, ANSI, UL, and NFPA standards.
3. The electrical contractor will provide permanent brass identification tags placed at each meter in the self-contained metering compartments in conformance with the requirements outlined in 5.13. Duplicated brass identification tags will be placed on the outside access doors of the self-contained metering compartments.
4. The instrument transformer (CT & VT) compartments shall have slotted bolts installed by customer or contractors in the instrument transformer (CT & VT) metering conduit. The minimum size for the instrument transformer (CT & VT) compartment shall be 30"x 30"x 10" deep to accommodate both the CTs and if required, the VTs (VTs are required for 277/480v services only).
5. All compartment exterior doors shall have a dual locking (padlock) provision.
6. A spare terminal (replacement) block shall be provided by the manufacturer for every five (5) self-contained meter sockets.
7. The CT meter conduit shall be no longer than **20 feet (total length of conduit including all bends)**. The conduit shall not have any conductors other than the required grounding/ bonding as shown in Drawing 17. Conduit must be contiguous from the meter socket to the switchgear CT cubicle, refer to paragraph 5.04e for instrument transformer conduit installation.
8. Slotted sealing screws required on front covers and removable panels as shown.
9. A supplemental electrode (driven ground rod) must be installed and bonded to the CT metering sockets if sockets are more than four (4) feet from the switchgear.
10. Arrangement of compartments (sections) may differ from what is shown depending on customer requirements and load considerations.
11. All conductors or buss on load side of disconnects are not to be routed or re-enter the line side of the instrument transformer (CT & VT) or metering compartments, including main disconnects.
12. Self-contained metering compartments are required to have a lever bypass at each meter terminal. Meter socket covers are to be the ringless type, with no outer doors or other material covering the meter. See 5.02d for mounting height requirements.
13. Sections rated over 200A up to 1200A shall accommodate bar-type CT's furnished by Colorado Springs Utilities; over 1200A shall accommodate window-type CT's furnished by Colorado Springs Utilities. See 5.04d) for mounting height and other requirements.
14. Section rated 277/480 volts shall accommodate a VT Pack furnished by Colorado Springs Utilities.
15. A junction box is required for any conduit run with over 270° of bends. Refer to NEC 314 for Junction Box Fill Calculations.

PHOTO 1 – THREE PHASE CT CABINET

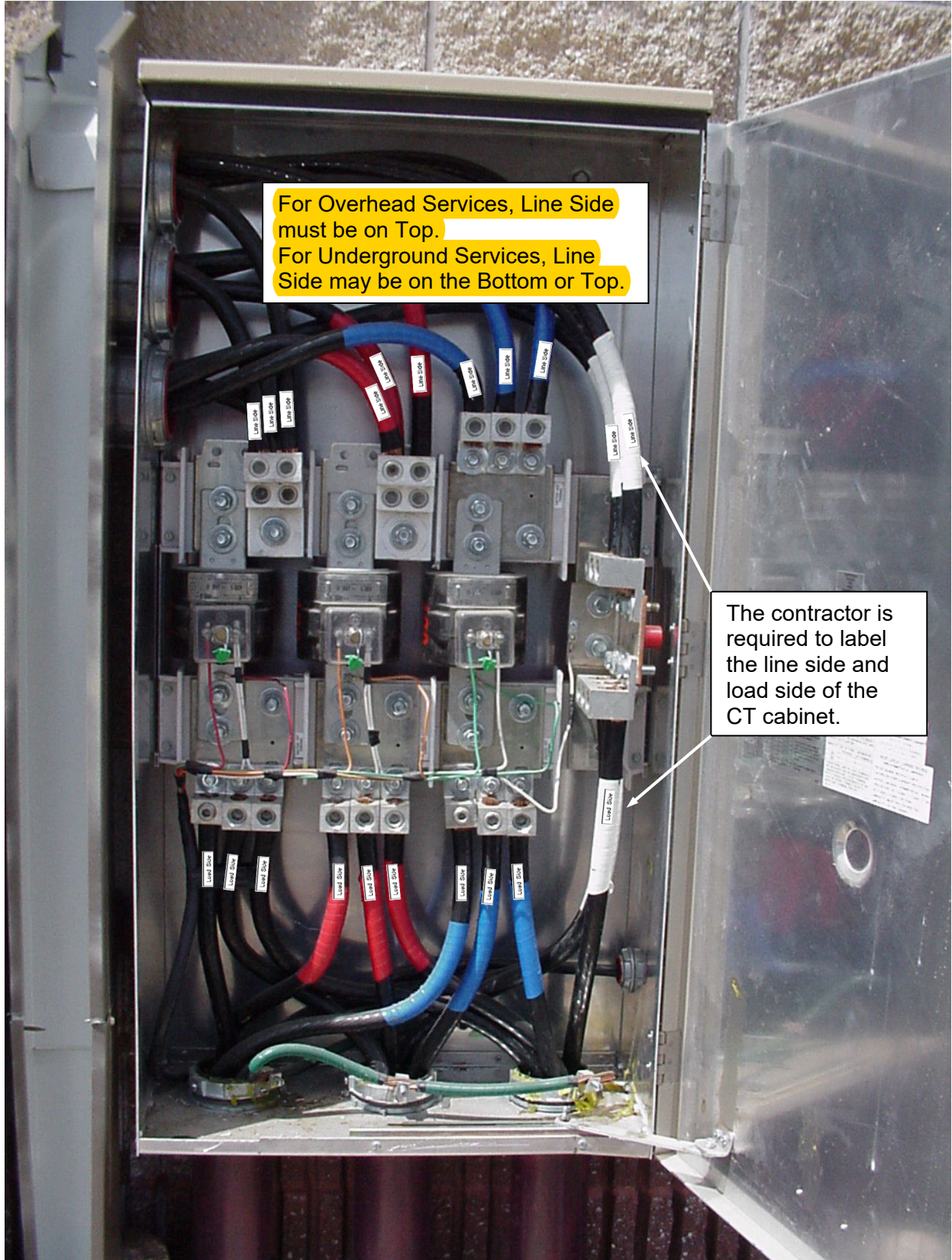
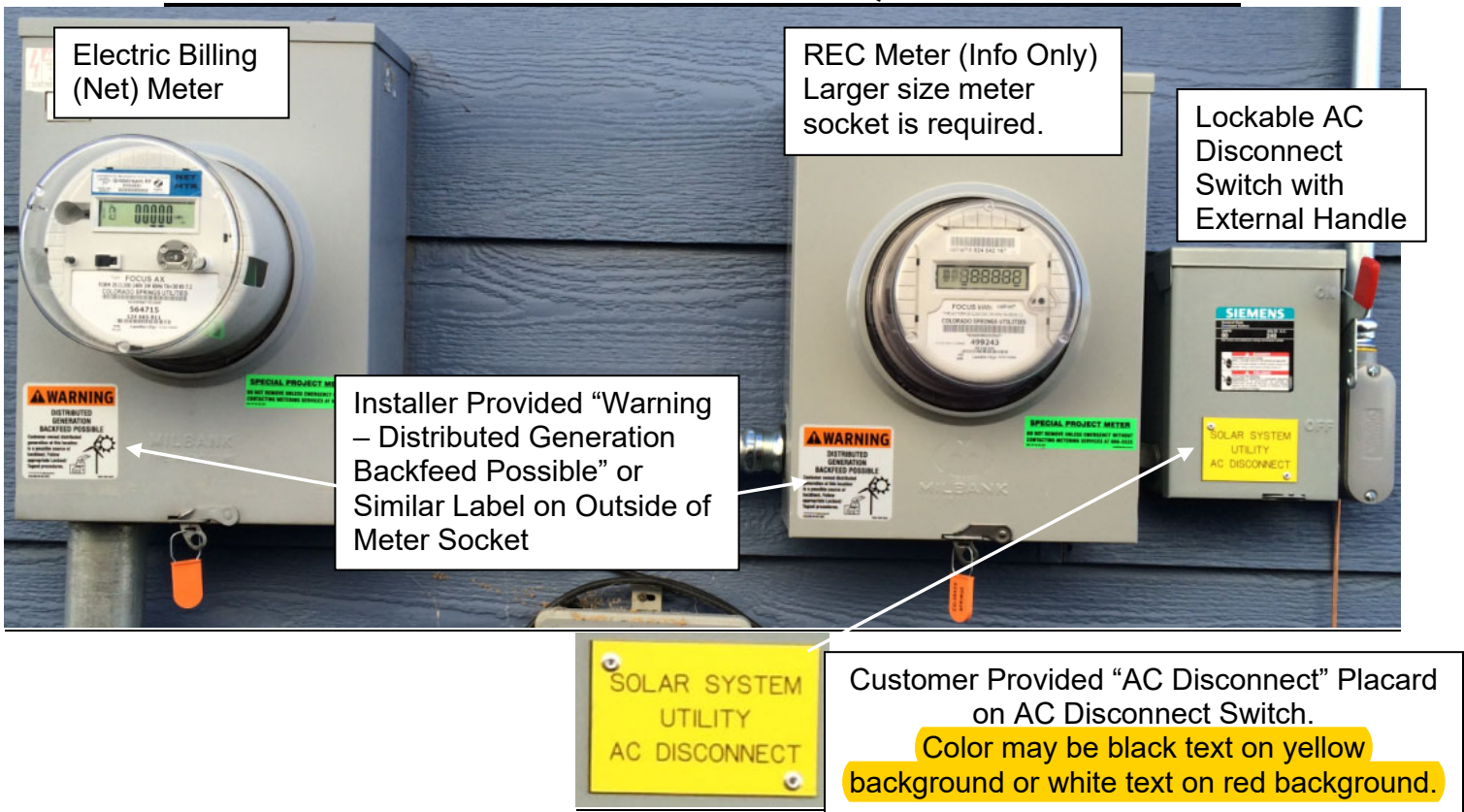
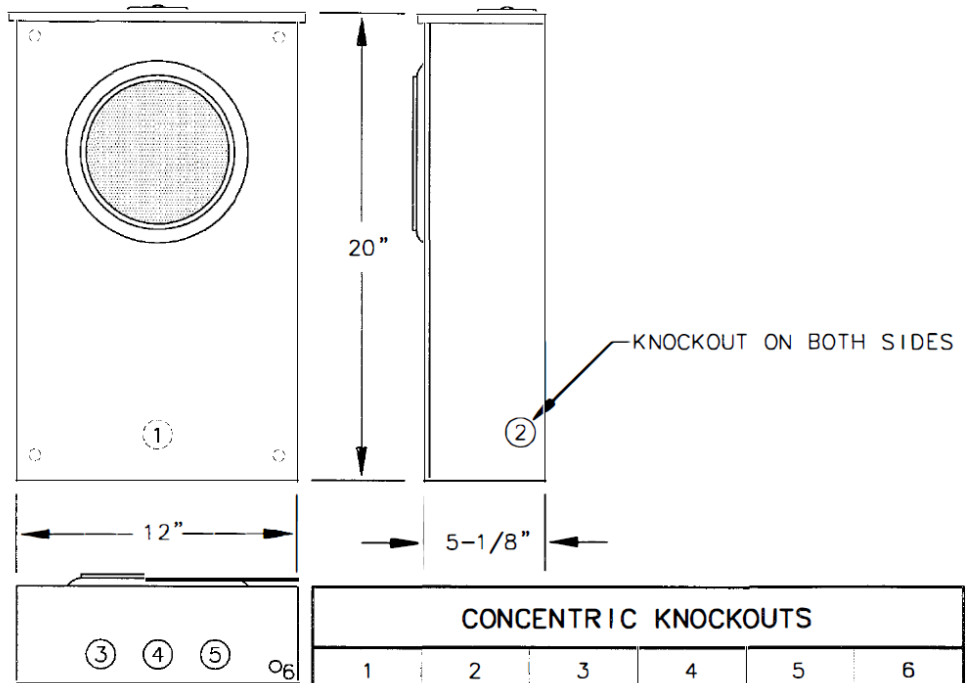

PHOTO 6 – PHOTOVOLTAIC SERVICE EQUIPMENT LABELING



Note: Various installations may require additional customer provided labeling.



NOTE :

Knockout dimensions are conduit trade sizes.

1. General.

- 1.1. Item Number(s): 102-600-070 Dated 3/14/2024
- 1.2. Description: Socket, Meter, Prewired Test Switch, 8 Terminal, 20 Amp
- 1.3. Where used: Mounting transformer rated watt-hour meters for single and three phase revenue metering
- 1.4. Material/Color: Galvanized Sheet Steel, Neutral Gray, Munsell #5BG7.0/0/4

2. Electrical & Mechanical Requirements.

- 2.1. Voltage Class/Rating: 600 V
- 2.2. Current rating: 20 A Continuous
- 2.3. Terminals shall be 10-32 stud type for ring tongue connectors.
- 2.4. The neutral terminal shall be electrically bonded to the enclosure by means of a bolted or riveted connection. A bonding jumper in the form of a separate screw, strap or other means shall bond the enclosure to the grounded (neutral) conductor using a #6 AWG copper or #4 aluminum wire.
 - 2.4.1. The neutral terminal shall accept the same conductor range as the current carrying terminals, see 2.6.
- 2.5. Wiring
 - 2.5.1. Current and potential terminals shall be wired from the top positions of the test switches to the socket terminals as shown in Figure 1.
 - 2.5.2. Conductors shall be thermoplastic-insulated #12 AWG stranded copper wire, using a Polyvinyl Chloride (PVC) covering, 10 mils in thickness and color coded as specified in 2.5.3; and shall be rated for 600 volts and 75° C; and terminated using a "Burndy HY" lug (catalog no. YAV10) or approved equal.
 - 2.5.3. Color coding of conductors shall be as listed below (see Figure 1):
 - (P1): A Potential – red with black tracer
 - (P2): B Potential – not wired
 - (P3): C Potential – green with black tracer
 - (PN): Potential Neutral – white with black tracer

- (C1): A Current line – red
- (C2): B Current line – not wired
- (C3): C Current line – green
- (C11): Current returns – white
- (C22): Current returns – not wired
- (C33): Current returns – white

2.6. Conductor Range: #14 through #4 AWG.

2.7. Terminals shall be suitable for use with both copper and aluminum conductors.

2.8. A stud type grounding terminal (1/4" x 20 UNC) for accepting ring-tongue connectors on #12 through #6 AWG conductors shall be located in the lower right corner below the test switch.

2.9. A test switch in accordance with Colorado Springs Utilities material specification 102-700-(000-001) shall be included.

3. Construction

3.1. The socket shall be constructed of 16 gauge or heavier galvanized sheet steel; 1 ¼ oz. class zinc-coated.

3.2. The cover shall be of the one piece ringless type, equipped with a suitable device for sealing with padlock type seals.

3.3. The finish shall be bonderized and coated with neutral gray (Munsell #5BG7.0/0/4) baked enamel.

3.3.1. The finish shall be uniform and even, free of runs, sags, checks or blisters.

3.4. Knockouts shall be concentric type with maximum size for 1-1/4" GRC conduit, located as shown in the diagram in on page 1/3, with the exception of the knockout for training of the ground wire which shall be ¼" in diameter.

3.5. Socket shall be provided with a bridge for mounting the test switch.

3.5.1. Alternate test switches are acceptable with prior written approval from Colorado Springs Utilities Engineering Standards.

3.6. Internal socket ground lug shall be located in the lower right hand corner below the bridge, as shown in Figure 1. (See electrical requirements, paragraph 2.8)

3.7. An external grounding pad (nut) shall be welded to the meter socket with a ½ inch 13NC hole 7/16 inches deep; and located as shown in the diagram on page 1/3.

3.8. Socket shall be weather-resistant and suitable for outdoor use with a removable hub closing plate on top.

4. Applicable Standards

4.1. The socket shall be constructed in accordance with and conform to the following publications.

4.1.1. ANSI/UL 414, "Standard for Meter Sockets", dated 2023 (Ninth Edition) or latest revision.

4.1.2. ANSI C12.7, "American National Standard Requirements for Watthour Meter Sockets", dated 2022 or latest revision.

4.1.3. ANSI C12.9, "American National Standard for Test Switches for Transformer Rated Meters", dated 2021 or latest revision.

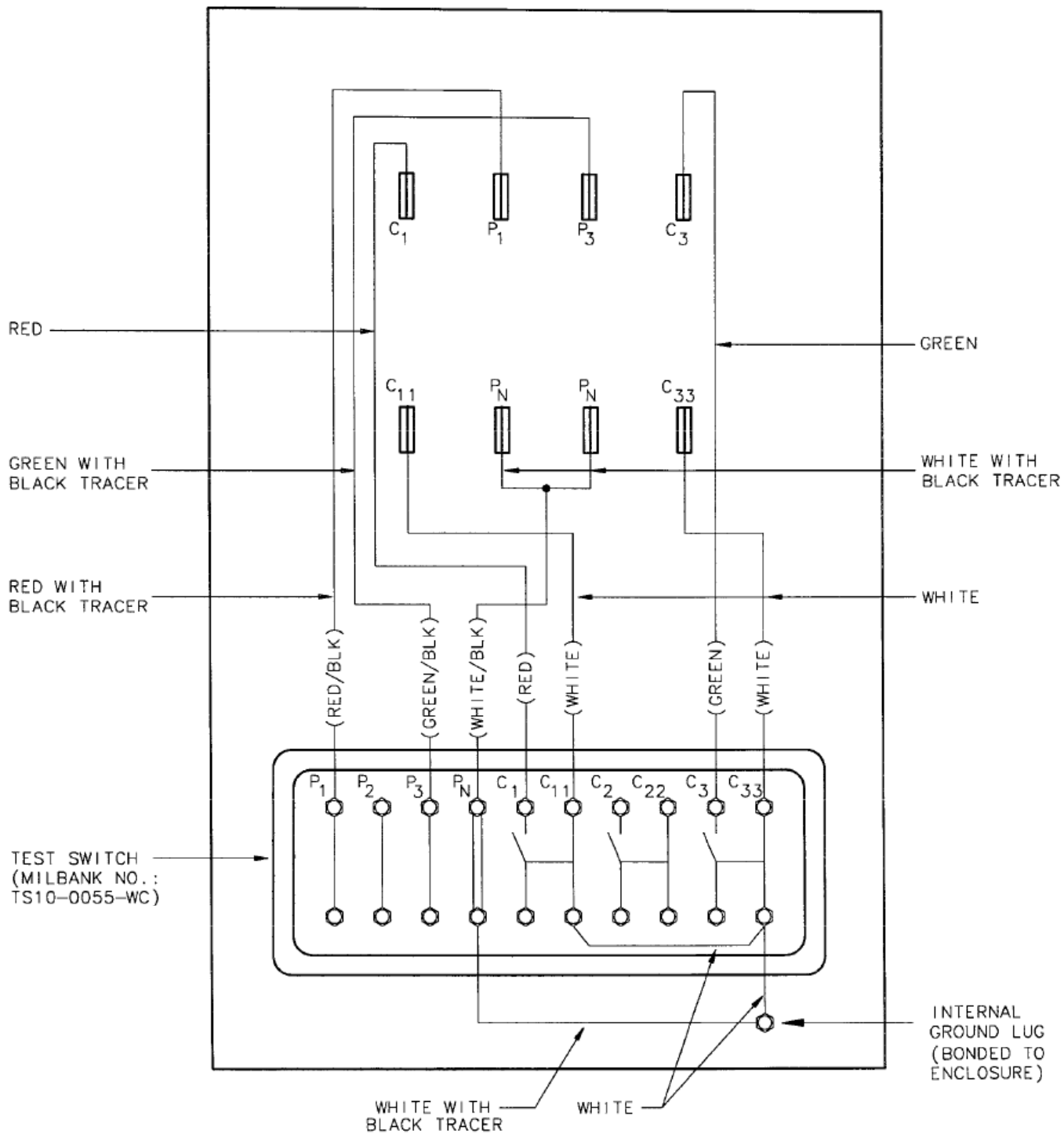
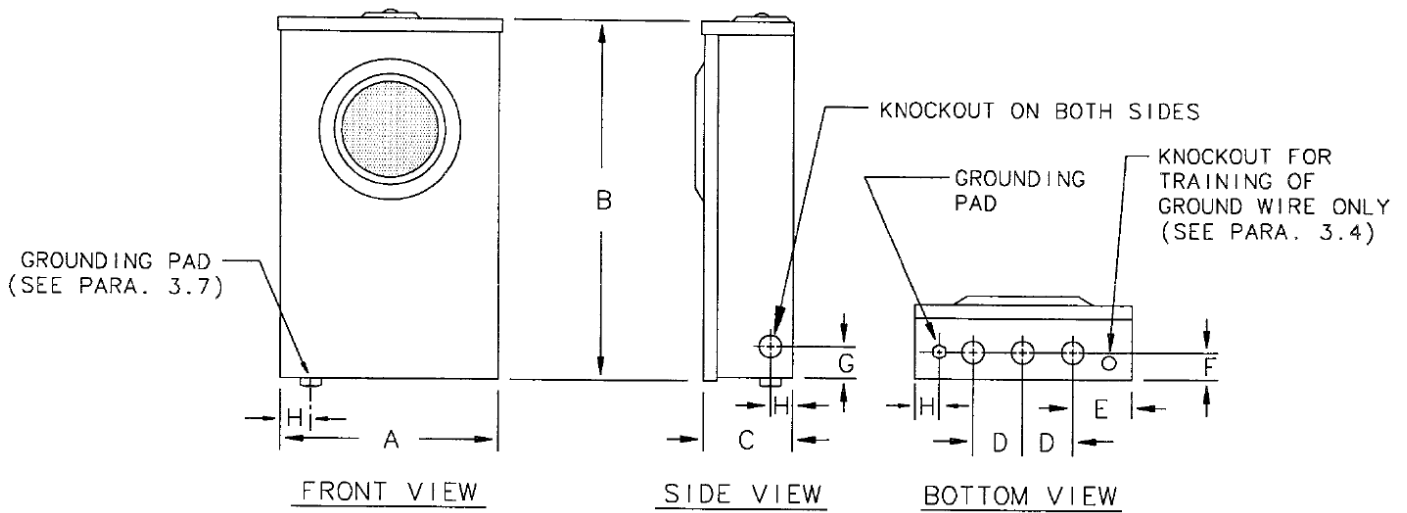

FIGURE 1



DIMENSIONS							
A	B	C	D	E	F	G	H
12	20	5-1/8	2-3/4	3-1/4	1-1/2	1-3/4	1-1/4

ALL DIMENSIONS IN INCHES

1. General.

- 1.1. Item Number(s): 102-600-077 Dated 3/14/2024
- 1.2. Description: Socket, Meter, Prewired Test Switch, 13 Terminal, 20 Amp
- 1.3. Where used: Mounting transformer rated watt-hour meters for single and three phase revenue metering
- 1.4. Material/Color: Bonderized Steel, Neutral Gray, Munsell #5BG7.0/0/4

2. Electrical & Mechanical Requirements.

- 2.1. Voltage Class/Rating: 600 V
- 2.2. Current rating: 20 A Continuous
- 2.3. Terminals shall be 10-32 stud type for ring tongue connectors.
- 2.4. The neutral terminal shall be electrically bonded to the enclosure by means of a bolted or riveted connection. A bonding jumper in the form of a separate screw, strap or other means shall bond the enclosure to the grounded (neutral) conductor using a #6 AWG copper or #4 aluminum wire.
 - 2.4.1. The neutral terminal shall accept the same conductor range as the current carrying terminals, see 2.6.
- 2.5. Wiring
 - 2.5.1. Current and potential terminals shall be wired from the top positions of the test switches to the socket terminals as shown in Figure 1.
 - 2.5.2. Conductors shall be thermoplastic-insulated #12 AWG stranded copper wire, using a Polyvinyl Chloride (PVC) covering, 10 mils in thickness and color coded as specified in 2.5.3; and shall be rated for 600 volts and 75° C; and terminated using a "Burndy HY" lug (catalog no. YAV10) or approved equal.
 - 2.5.3. Color coding of conductors shall be as listed below (see Figure 1):
 - (P1): A Potential – red with black tracer
 - (P2): B Potential – orange with black tracer
 - (P3): C Potential – green with black tracer
 - (PN): Potential Neutral – white with black tracer

- (C1): A Current line – red
- (C2): B Current line – orange
- (C3): C Current line – green
- (C11): Current returns – white
- (C22): Current returns – white
- (C33): Current returns – white

2.6. Conductor Range: #14 through #4 AWG.

2.7. Terminals shall be suitable for use with both copper and aluminum conductors.

2.8. A stud type grounding terminal (1/4" x 20 UNC) for accepting ring-tongue connectors on #12 through #6 AWG conductors shall be located in the lower right corner below the test switch.

2.9. A test switch in accordance with Colorado Springs Utilities material specification 102-700-(000-001) shall be included.

3. Construction

3.1. The socket shall be constructed of 16 gauge or heavier galvanized sheet steel; 1 ¼ oz. class zinc-coated.

3.2. The cover shall be of the one piece ringless type, equipped with a suitable device for sealing with padlock type seals.

3.3. The finish shall be bonderized and coated with neutral gray (Munsell #5BG7.0/0/4) baked enamel.

3.3.1. The finish shall be uniform and even, free of runs, sags, checks or blisters.

3.4. Knockouts shall be concentric type with maximum size for 1-1/4" GRC conduit, located as shown in the diagram on page 1/3, with the exception of the knockout for training of the ground wire which shall be ¼" in diameter.

3.5. Socket shall be provided with a bridge for mounting the test switch.

3.5.1. Alternate test switches are acceptable with prior written approval from Colorado Springs Utilities Engineering Standards.

3.6. Internal socket ground lug shall be located in the lower right hand corner below the bridge, as shown in Figure 1. (See electrical requirements, paragraph 2.8)

3.7. An external grounding pad (nut) shall be welded to the meter socket with a ½ inch 13NC hole 7/16 inches deep; and located as shown in the diagram on page 1/3.

3.8. Socket shall be weather-resistant and suitable for outdoor use with a removable hub closing plate on top.

4. Applicable Standards

4.1. The socket shall be constructed in accordance with and conform to the following publications.

4.1.1. ANSI/UL 414, "Standard for Meter Sockets", dated 2023 (Ninth Edition) or latest revision.

4.1.2. ANSI C12.7, "American National Standard Requirements for Watthour Meter Sockets", dated 2022 or latest revision.

4.1.3. ANSI C12.9, "American National Standard for Test Switches for Transformer Rated Meters", dated 2021 or latest revision.

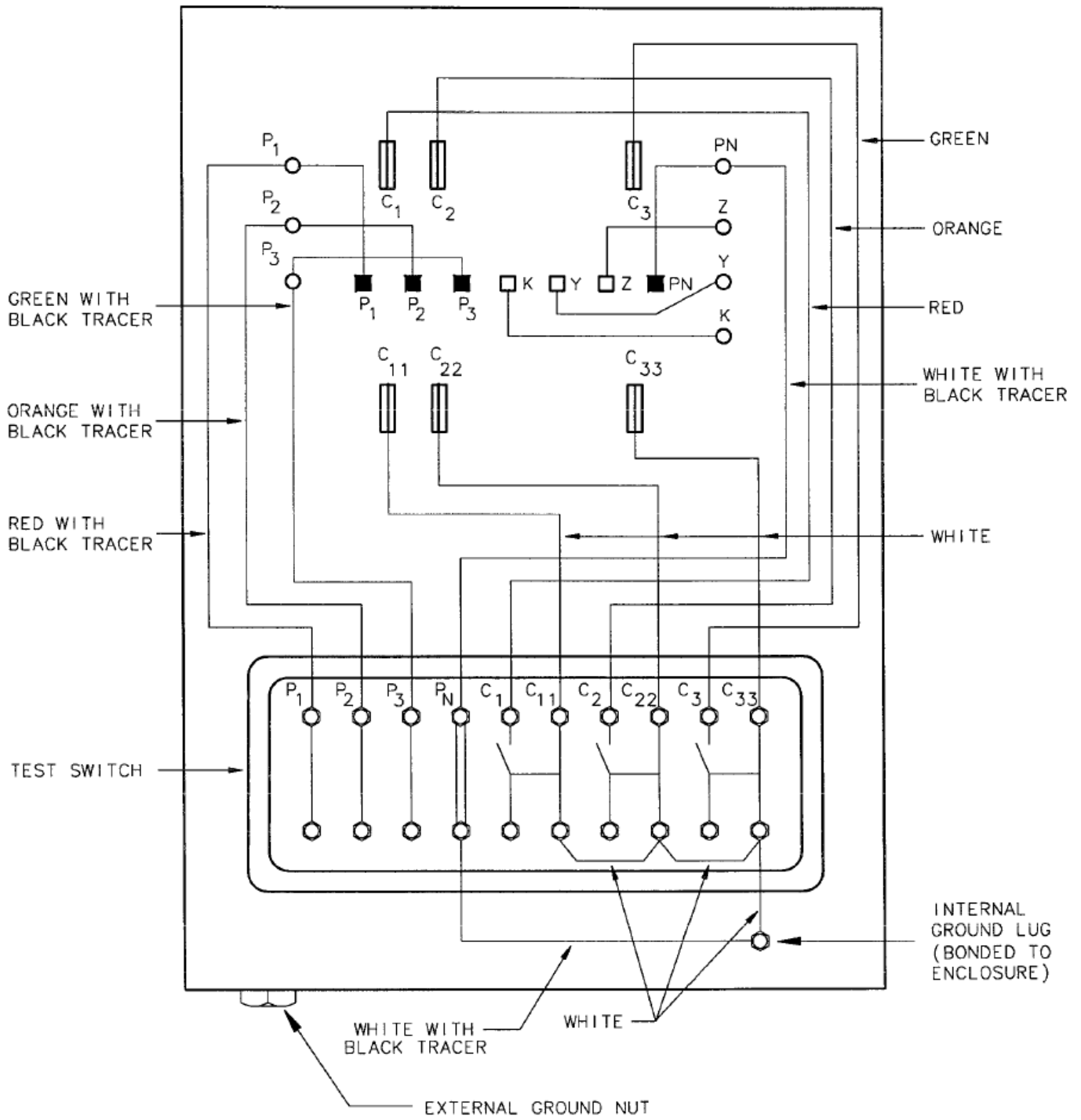
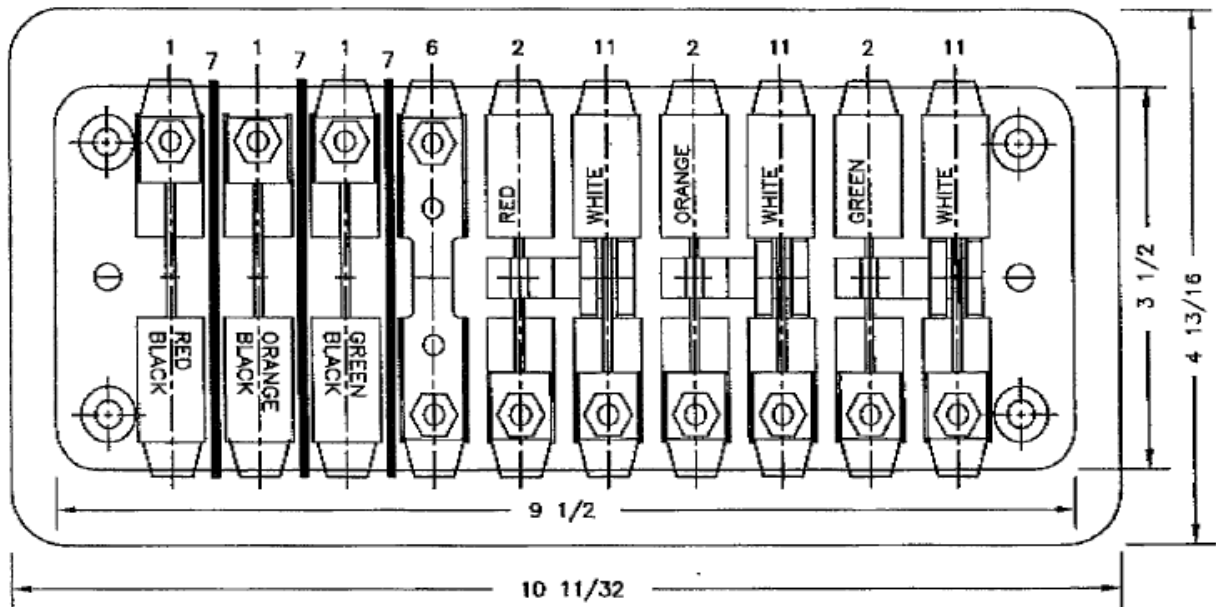

FIGURE 1



1. General

- 1.1. Item Number: 102-700-(000-001) dated 03/14/2024
- 1.2. Item Description: Switch, Color Coded Meter Test – (VARIES) Connected
- 1.3. Long Description: In Conformance with CSU Material Specification 102-700-(000-001) dated 02/02/2015
- 1.4. Where Used: Electric Revenue Meter C.T. and P.T. testing switch.

2. In Conformance with the following Standards

- 2.1. ANSI: C12.9

3. Electrical & Mechanical Requirements

- 3.1. Insulation Rating(s): 600 VAC
- 3.2. Continuous Current Rating: 30 A

4. Optional Features and Functions Included

- 4.1. Front Connected Wire Connections for item 102-700-000 and Back Connected Wire Connections for item 102-700-001.
- 4.2. Ten Position Switch Layout from left to right is:
 Potential (Red w/Black), Potential (Orange w/Black), Potential (Green w/Black),
 Neutral (No Color - Solid), Shorting Switch (Red), Test Jack (White), Shorting Switch (Orange),
 Test Jack (White), Shorting Switch (Green) and Test Jack (White).
 - 4.2.1. Potential switches shall open upward.
 - 4.2.2. Current switches shall open downward.
- 4.3. Current Carrying components are tin plated.
- 4.4. Clear Lexan Cover.

Colorado Springs Utilities

Specification 193-SPP-SCA

For

GENERATION POWER PLANT SCADA PANELS

Approved by Engineering Standards:

Approved by Electric Distribution Control:

Approved by Relay, Instrumentation, and Control:

Approved by Network Infrastructure Services:

Approved by Substation and Transmission Engineering:

Approved by Measurement Engineering:

Written by: Melissa Garza

Date: 09/20/2018

Drawn by: Jonathon O'Donoghue

Date: 11/22/2023

Original Effective Date: 09/25/2018

Revision no: 1

Revision Date: 8/3/2023

Revision no: 2

Revision Date: 9/22/2023

Revision no: 3

Revision Date: 10/4/2023

Revision no: 4

Revision Date: 11/17/2023

Revision no: 5

Revision Date: 12/18/2023

Revision no: 6

Revision Date: 6/3/2024



1. Scope

This specification establishes requirements for electrical and mechanical performance, interchangeability, and safety of the equipment covered. This specification covers the requirements of SCADA panels for Generation Power Plants requiring primary metering for production and not interconnecting with other utilities or power authorities.

2. General

- 2.1 Description: Panel, SCADA, Solar Array, Wind, Battery Storage Systems.
- 2.2 Unit of Measure: Each
- 2.3 Use: For indication metering and statuses of Generation Power Plants.

3. Referenced Standards

Equipment/material covered by this specification shall be manufactured in conformance with the following standards including all standards referenced therein. It shall also comply with all other applicable standards of IEEE, ANSI, ASTM, NEMA, UL, and similar industry organizations. Where conflicts occur in referenced standards, the more stringent shall apply unless modified by this specification. The revisions in effect on the date of the order or blanket release shall apply. The term "approved equal" shall mean approved in writing by the Colorado Springs Utilities, Engineering Standards.

- 3.1 American National Standards Institute (ANSI), Institute of Electrical and Electronics Engineers (IEEE), National Fire Protection Association (NFPA), or UL latest edition:
 - 3.1.1 ANSI C2, "National Electrical Safety Code."
 - 3.1.2 IEEE 929 "Recommended Practice for Utility Interface of Photovoltaic (PV) Systems"
 - 3.1.3 NFPA 70: "National Electric Code (NEC)"
 - 3.1.4 NFPA 70E: "Standard for Electrical Safety in the Workplace"
 - 3.1.5 UL 1741 Standard for Safety for Inverters, Converters, Controllers and Interconnection System Equipment for Use with Distributed Energy Resources
 - 3.1.6 NEMA 250: "Enclosures for Electrical Equipment"

4. Performance Requirements

- 4.1 The enclosures shall be a 36" x 48" x 16" SCADA enclosure with a swing out panel kit.
- 4.2 Any generation site that is 150 kW and greater, but less than 500 kW in size requires an Aclara KV2c meter. Any generation size equal to or greater than 500 kW in size requires an SEL-735 meter.
- 4.3 The SCADA Panel will be used to perform indication metering of Generation Power Plants with analog points for various parameters including:
 - 4.3.1 Total kW
 - 4.3.2 Total kvar
 - 4.3.3 Total kVA
 - 4.3.4 I_n (neutral) current
 - 4.3.5 Frequency
 - 4.3.6 Maximum kW import sliding window demand
 - 4.3.7 kW import accumulated demand
 - 4.3.8 Maximum kVA sliding window demand
 - 4.3.9 kVA accumulated demand
 - 4.3.10 I_1 maximum ampere demand
 - 4.3.11 I_2 maximum ampere demand
 - 4.3.12 I_3 maximum ampere demand
 - 4.3.13 kWh import
 - 4.3.14 kWh export
 - 4.3.15 kvarh net
 - 4.3.16 kVAh
 - 4.3.17 kvarh import



- 4.3.18 kvarh export
- 4.3.19 phase 1-N volts
- 4.3.20 phase 2-N volts
- 4.3.21 phase 3-N volts
- 4.3.22 phase 1 amps
- 4.3.23 phase 2 amps
- 4.3.24 phase 3 amps
- 4.3.25 phase 1 kW
- 4.3.26 phase 2 kW
- 4.3.27 phase 3 kW

4.4 Meter shall provide 5-minute interval data including:

- 4.4.1 kWh Delivered
- 4.4.2 kVAR Delivered
- 4.4.3 kVAR Received
- 4.4.4 kWh Received

4.5 The SCADA Panel will be used to perform status indication of Generation Power Plants with digital points for various parameters including:

4.5.1 Breaker status (only applicable if generation site is 500 kW or larger)

4.5.1.1 Customer will need to install 52a contacts on their breaker and hardwire into the customer-owned RTU. This enables "soft points" to be sent to the Utilities' RTU.

4.5.2 Load switch status (only applicable if generation site is 500 kW or larger)

4.5.2.1 Customer will need to install 89a contacts on their load switch and hardwire into the customer-owned RTU. This enables "soft points" to be sent to the Utilities' RTU.

4.5.3 RTU status

4.6 The SCADA Panel shall perform those functions as well as other service imposed duties within ratings without deterioration below design ratings during its useful service life.

4.7 The SCADA Panel shall be designed for a useful service life of at least 30 years. The failure rate over the useful service life shall not exceed 0.1% per year.

4.8 Soft data points to be provided by the customer's RTU.



- 4.8.1 For Solar Arrays and Wind Generation, weather data points, from a weather station or other sensors, are to be provided at 4-second intervals, unless otherwise stated, to include:
 - 4.8.1.1 Wind speed - Telemetered wind speed measured in meters per second (m/s) taken directly from the specified meteorologic station.
 - 4.8.1.2 Wind direction - Telemetered wind direction measured in compass heading degrees (1 – 360) taken directly from the specified met station.
 - 4.8.1.3 Air Temp - Telemetered air temperature measured in degrees Celsius (C) taken directly from the specified met station.
 - 4.8.1.4 Barometric pressure - Telemetered barometric pressure measured in kilopascals (kPa) taken directly from the specified met station.
 - 4.8.1.5 Relative Humidity - Telemetered relative humidity measured in percent (%) taken directly from the specified met station.
 - 4.8.1.6 Back panel temp - Telemetered temperature measured in degrees Celsius (C) taken from a thermocouple probe attached to the back of a unit.
 - 4.8.1.7 Irradiance - Telemetered irradiance measured in watt per square meter (W/m²) required for the type of technology that is employed.
 - 4.8.1.8 Irradiance requirements may be a combination of direct irradiance, global horizontal irradiance, or plane of array/global irradiance.
- 4.8.2 Real-Time Availability - Percentage of installed nameplate capacity of the generation site that is able to generate power. A snapshot of the instantaneous availability at the generation site is required at a maximum periodicity of 60 seconds.
- 4.8.3 Real-Time Capability - The amount (MW) of real power output the resource is capable of instantaneously producing, excluding any dispatch, deployment, or curtailment instructions. This item is only required for resources that are qualified to provide operating reserve. (This only applies if there is control through the SCADA system for generation sites that are 10MW or larger.)
- 4.8.4 A market Participant for a generation site must provide planned and forced outage and availability data through the Control Room Operations Window (CROW).
- 4.8.5 For Battery Storage Systems, state of charge in real time.

5. Unusual Service Conditions

- 5.1 All materials used shall be suitable for operating temperature of between -20°C to 60°C (-4 °F to 140 °F).
- 5.2 SCADA Panels shall be suitable for operation in air up to an elevation of at least 7500 feet above sea level and resistant to UV degradation that would shorten expected useful service life.

6. Testing Requirements

- 6.1 Design and production testing shall be performed as specified by the ANSI and IEEE standards referenced herein.

7. Construction Requirements

- 7.1 Dimensions
 - 7.1.1 Overall SCADA cabinet, conduit, and grounding shall conform to dimensions as indicated in Figure 1 shown below.



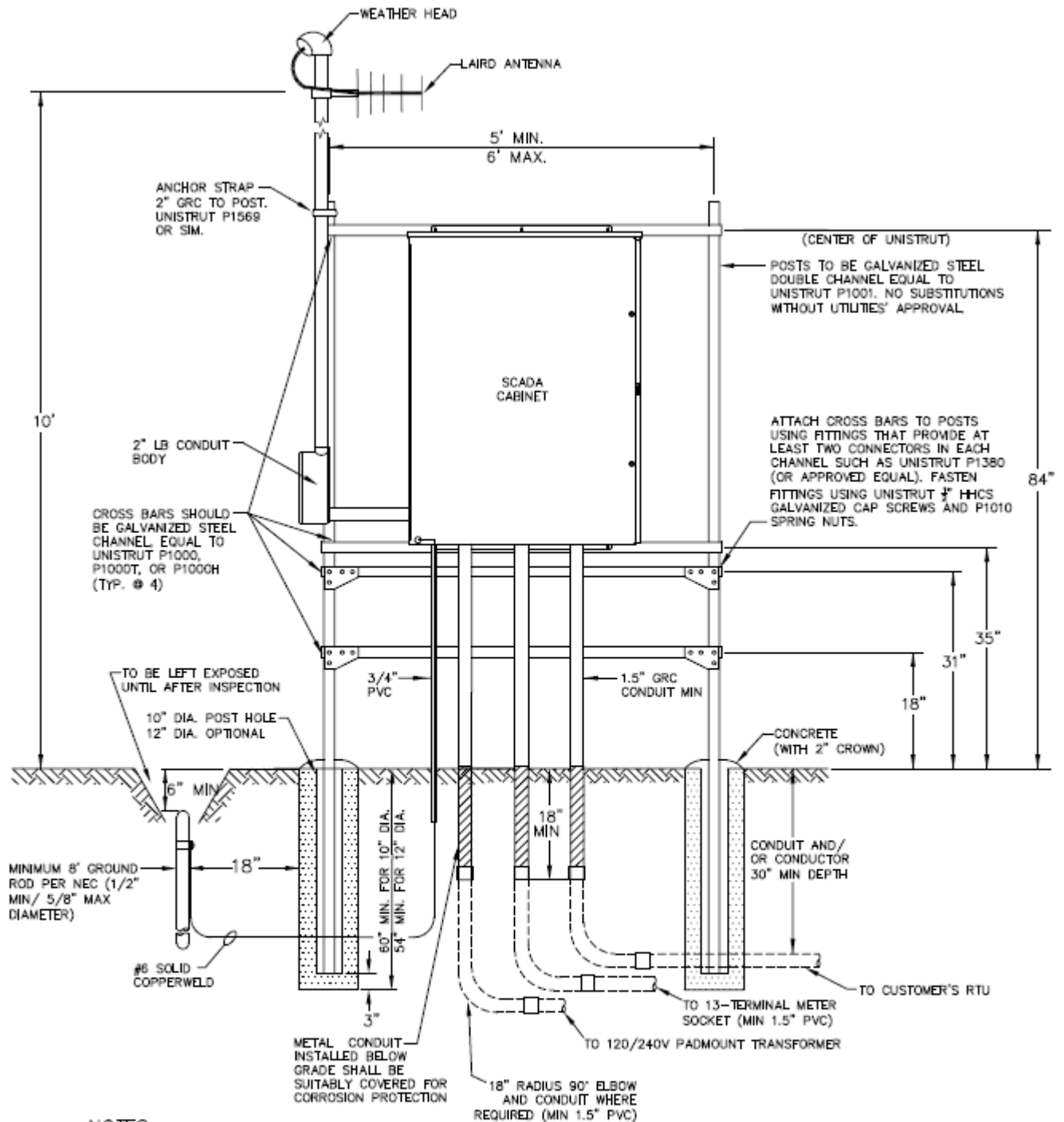

NOTES:

1. Enclosure requires grounding to ground rod. Cabinet doors to be grounded.
2. Maintain 3' clearance in front of meter and 2' clearance at sides of meter.
3. GRC riser conduit must extend 18" below final grade, minimum.
4. Ground conduits to cabinet per CSU Substation Construction Standard 8-8
5. Assembly piece sizes, dimensions, and foundation are based on support of a cabinet up to 36" wide, 48" tall and 16" deep with a total installed weight of approx. 230 lbs. Further evaluation is recommended for any installations deviating from these conditions.
6. Touch up all field drilled holes and/or cut edges with galvanizing spray.

Figure 1: SCADA cabinet, conduit, and grounding details



7.2 Material List

7.2.1 Overall SCADA Panel shall consist of the materials as listed in Table 1 on page 6.

Material List

Item	Qty	Description	Manufacturer Part No.	CSU Part No.
1	1	SEL-735 Electric Meter	0735HX10944CFDXXX16101XX	*
2	1	SEL-3061 Cellular Router (Includes omnidirectional antennas, surge suppressor, and coaxial cables)	3061#NC6L	*
3	2	2' SEL-C980 Coaxial RG-8 Cables (SMA Male/N-Type Male)	C980#42NN (C980-02)	*
4	1	TEST SWITCH FOR SEL-735 METER	ABB: C9652A25G01	193-900-386
5	1	Cover, Test Switch, Standard, Individual, Deep Cover, Clear		193-900-378
6	1	GE Orbit Licensed Narrowband 450-520 MHz Frequency Range: 450 to 520 MHz 1 Ethernet, 2 Serial Din Rail Mount w/ 120V POWER SUPPLY	GE Orbit MCR: MXNXL4CNNNNNNS2F9DUNN	TELECOM *
7	1	450-470MHz 7.1dB 3 Element Yagi Antenna	Y4503	TELECOM *
8	1	Antenna Surge Suppressor	POLYPHASER CO.: IS-B50LN-C2	TELECOM *
9	4	N M Hex/Knurl Combo No Braid Trim LMR400	EZ-400-NMH-X	TELECOM *
10	1	3 ft TWS-240 N Female to TNC Male	T3RFC-16187-36	TELECOM *
11	1	Fiber to Copper Media Converter w/ Din Rail Mount Bracket	Transition Networks - J/RS232-CF-01(SC)-NA	TELECOM *
12	1	Cabeling from Radio to Antenna		TELECOM *
13	2	Custom CAT 5 cable (RJ45/RS232) (Made in-house so no cost)		TELECOM *
14	1	CAT 5 cable (RJ45/RJ45)		TELECOM *
15	1	120V AC to 24V DC Power Supply	MEAN WELL MDR-60-24	*
16	1	200 Watt, W/Fan Temperature Activated Positive Temperature Heater	WAUKESHA SERVICE & COMPONENTS: PTC2-H02	*
17	1	2-Gang Metal Square Electrical Box	RACO - 70965	*
18	1	2-Gang Metal Square Electrical Box Cover	RACO - 72449	*
19	1	GFCI Duplex Receptacle	LEVITON: 7899-I	194-106-092
20	1	2-Gang Wall Plate	Eaton - 97918	*
21	1	15A Single Pole Toggle Light Switch	Eaton - 70610	*
22	1	Hoffman Comapct LED Light	Hoffman: CEL550	*
23	1	Hoffman Compact LED Light Mounting Magnets	Hoffman: CELA02MF	*
24	1	Hoffman Compact LED Light Connection Cable	Hoffman: CELC3001PBUL	*
25	1	48X36X16 Medium Drip-Shield Hinged-Cover Type 3R Hoffman	Hoffman: A48R3616HCR	*
26	1	Swing-Out Panel Kit for Wall-Mount Enclosure	Hoffman: ANADFK	*
27	2	Steel Panel for Type 3R Enclosure	Hoffman: A48P36	*
28	2	Grounding Lug Kit	Hoffman: AGLK2	*
29	1	GROUNDING KIT, HOFFMAN ENCLOSURE CABINET	HOFFMAN ENGINEERING COMPANY: 99411400	193-100-907
30	1	3-POLE FINGERSAFE STYLE FUSEHOLDER	FERRAZ SHAWMUT: USM3	193-100-602
31	6	1-POLE FINGERSAFE STYLE FUSEHOLDER		193-100-600
32	1	BLOCK, TERMINAL, SHORTING, (4 POSITION)		193-100-170
33	11	MODULAR TERMINAL BLOCK WITH STACKABLE SECTIONS (35 MM DIN RAIL)	IDEC CORPORATION: BNH30W	193-100-150
34	2	MODULAR TERMINAL BLOCK END STOP (35MM DIN RAIL)	IDEC CORPORATION: BNE30W	193-100-155
35	17	MODULAR TERMINAL BLOCK END CLAMP (35MM DIN RAIL)	IDEC CORPORATION: BNL5	193-100-157
36	9	MODULAR TERMINAL BLOCK SNAP ON LABEL (35MM DIN RAIL)	ABB: 0116 914.00, OR ENTRELEC: PEBP 0116 914.00	193-100-151
37	2	FUSE, MIDGET FAST ACTING 1-1/2" X 13/32" (1A)	COOPER BUSSMAN: BAF-1, LITTLE FUSE: BLF-1, OR FERRAZ SHAWMUT: ATM-1	193-100-610
38	3	FUSE, MIDGET FAST ACTING 1-1/2" X 13/32" (2A)	COOPER BUSSMAN: BAF-2, LITTLE FUSE: BLF-2, OR FERRAZ SHAWMUT: ATM-2	193-100-612
39	2	FUSE, MIDGET FAST ACTING 1-1/2" X 13/32" (3A)	COOPER BUSSMAN: BAF-3, LITTLE FUSE: BLF-3, OR FERRAZ SHAWMUT: ATM-3	193-100-613
40	1	FUSE, MIDGET FAST ACTING 1-1/2" X 13/32" (20A)	COOPER BUSSMAN: BAF-20, LITTLE FUSE: BLF-20, OR FERRAZ SHAWMUT: ATM-20	193-100-630
41	1	FUSE, MIDGET FAST ACTING 1-1/2" X 13/32" (30A)	COOPER BUSSMAN: BAF-30, LITTLE FUSE: BLF-30, OR FERRAZ SHAWMUT: ATM-30	*
42	165	WIRE, SIS #12 for CT Wiring and General Wiring Inside Scada Enclosure		193-650-012
43	35	WIRE, SIS #12 for Ground Wiring		193-650-014
44	2	#12 yellow termination lugs		193-500-515



ELECTRIC DISTRIBUTION MATERIAL SPECIFICATION

APPROVED AS OF:
6/3/2024

SCADA Panels for Solar Power Plants

193-SPP-SCA

PG. 6/13

45	1	Cable Tie Mounts	850-900-072
46	1	Zip Ties	(Minor Material)
47	2	RAIL, DIN TYPE, MOUNTING TRACK, SLOTTED, 35MM X 7.5MM, 1 METER (39.4")	193-900-005
48	20	CABLE, CONTROL, 10 CONDUCTOR, 600V, #12, K1 COLOR CODE PER ICEA AND NEC	102-900-100
49	3	TRANSFORMER, CURRENT 15KV OUTDOOR 200/400:5	102-800-032
50	3	TRANSFORMER, VOLTAGE 7.2KV 110KV BIL 60:1	102-900-000
51	25	CABLE, CONTROL, 10 CONDUCTOR, 600V, #12, K1 COLOR CODE PER ICEA AND NEC	102-900-100
52	20	WIRE, 1/0 BLACK XHHW, 600V, COPPER, 19 STR, 500'	190-652-100
53	1	KIT, CABLE SUPPORT BRACKET ASSEMBLY, 71" CHANNEL AND TWO ANGLE FITTINGS	194-105-112
54	1	COVER, VAULT, CONCRETE, WITH (1) 17"X 64" KNOCKOUT & (1) 17"X 69" WINDOW, 10"X 81"X 84" (A LID)	194-115-103
55	1	COVER, VAULT, CONCRETE, WITH 36" RING & MANHOLE COVER 84"X 81"X 10" (B LID)	194-115-115
56	10	WIRE, 2/0, COPPER, BARE 19 STR, 1000'	194-117-102
57	1	VAULT, PRECAST CONCRETE 6" X 12'-6" X 7'	194-115-106
58	1	CABINET, PRIMARY METERING PADMOUNT 15KV	194-107-150
59	1	SOCKET, METER PREWIRED TEST SWITCH 13 TERMINAL	102-600-077

Table 1: SCADA Panel and Primary Meter Enclosure Material List

7.3 Electrical

7.3.1 Overall SCADA Panel shall be wired as shown in Figures 2-7 on pages 7-12.

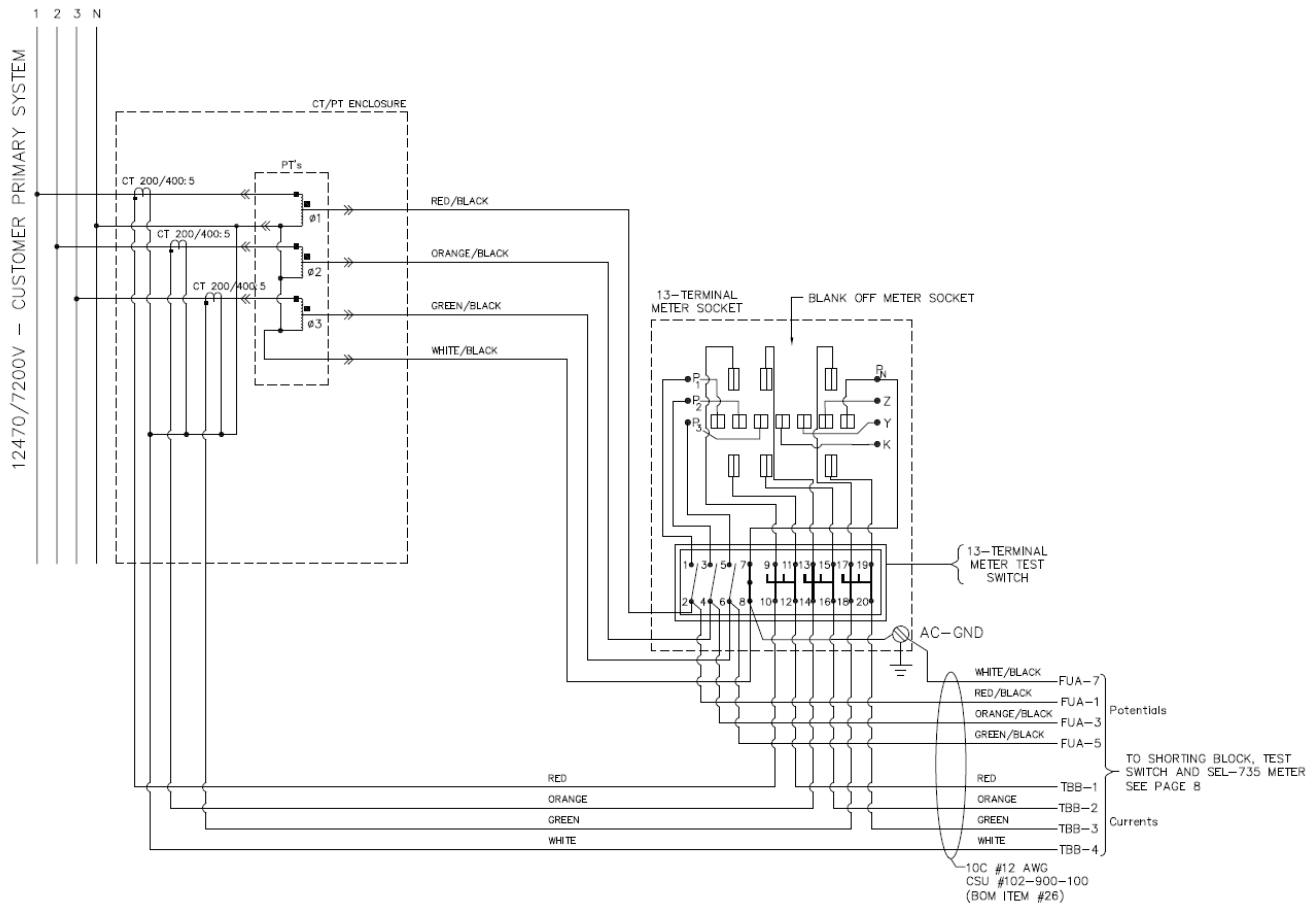

Figure 2: Revenue Metering Three-Line (CSU Reference Only)



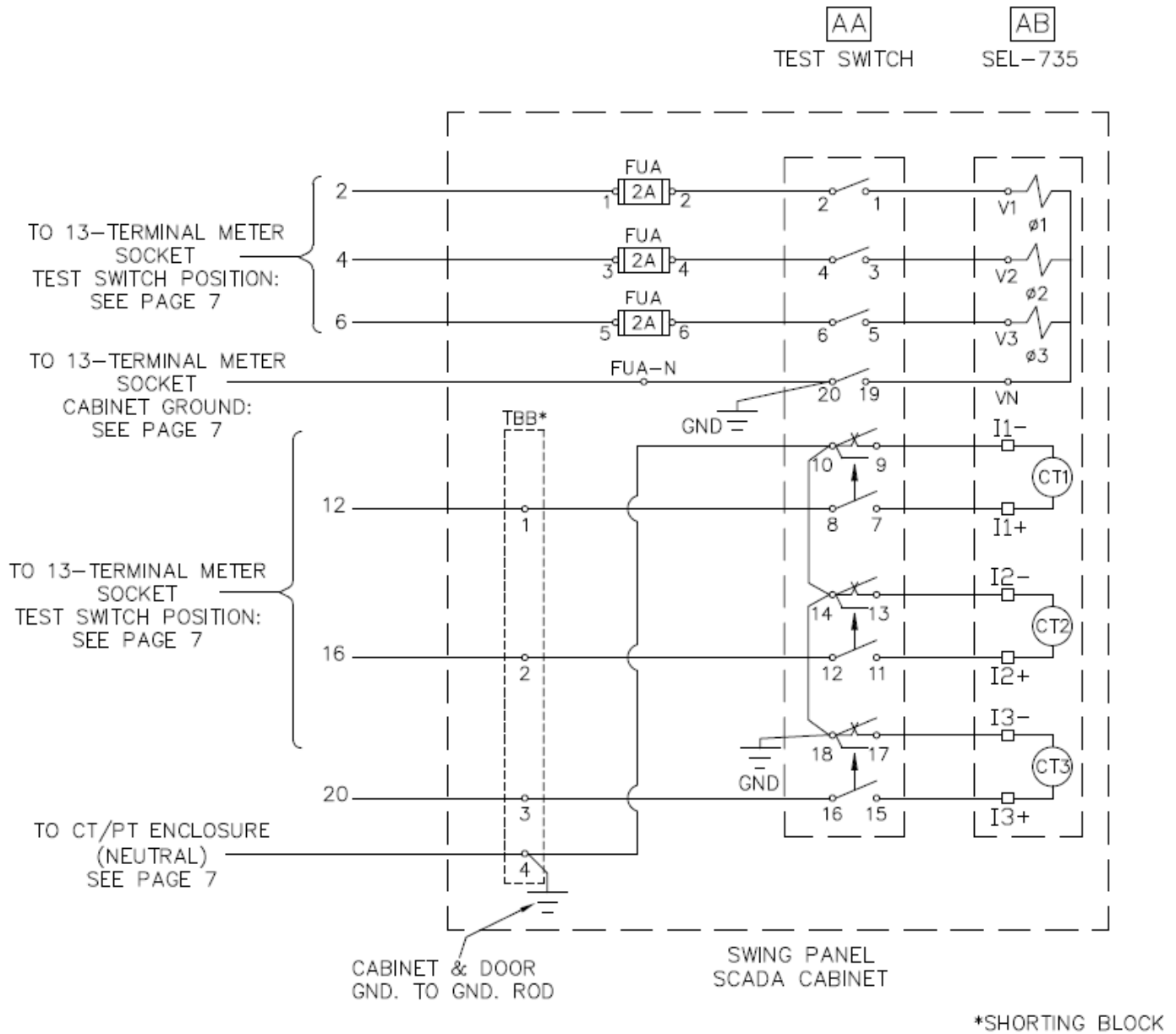

Figure 3: SCADA Cabinet Three-Line

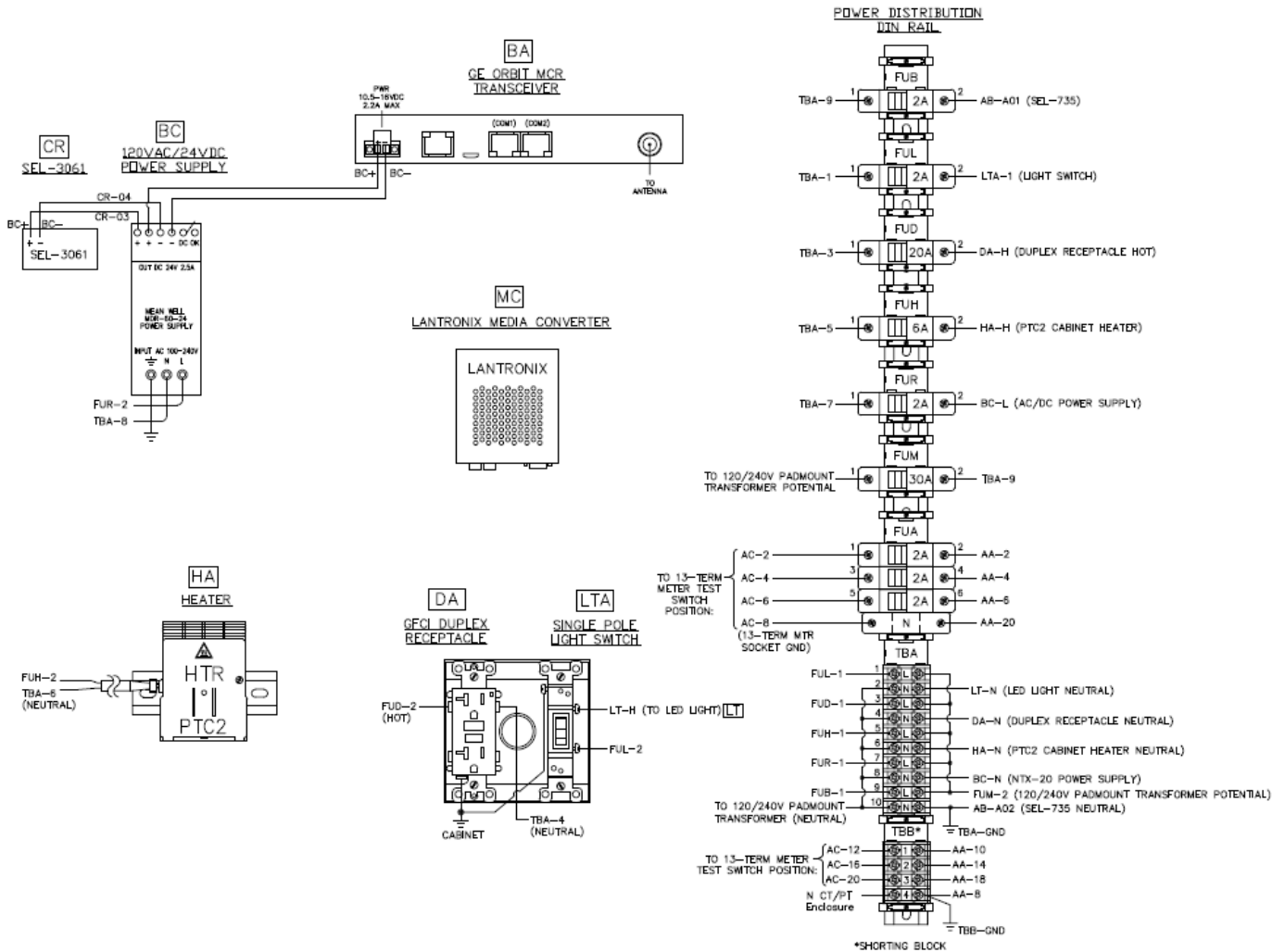

Figure 4: SCADA Cabinet Wiring Diagram

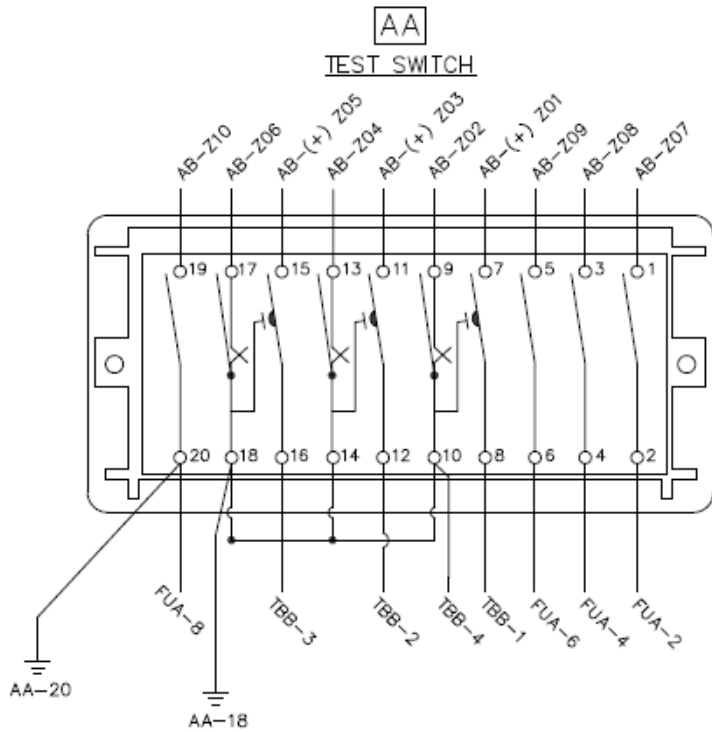
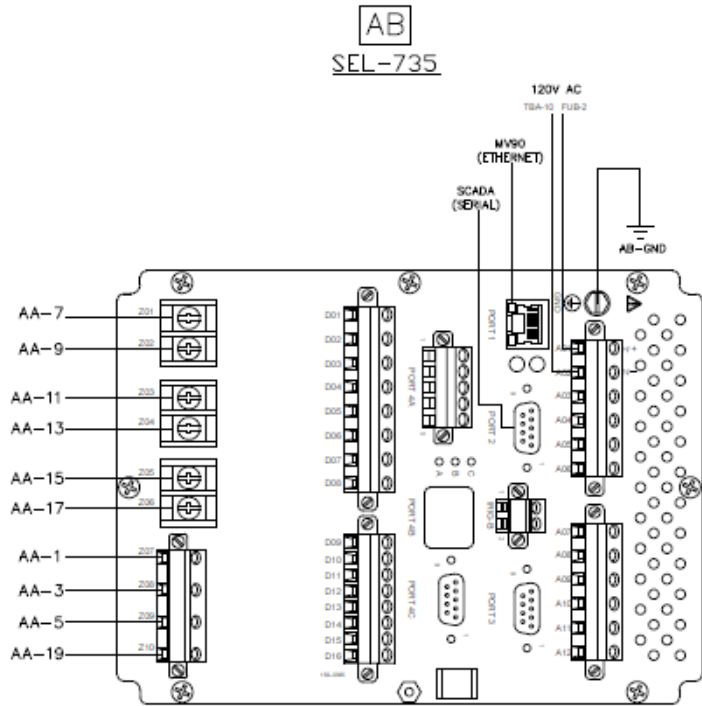
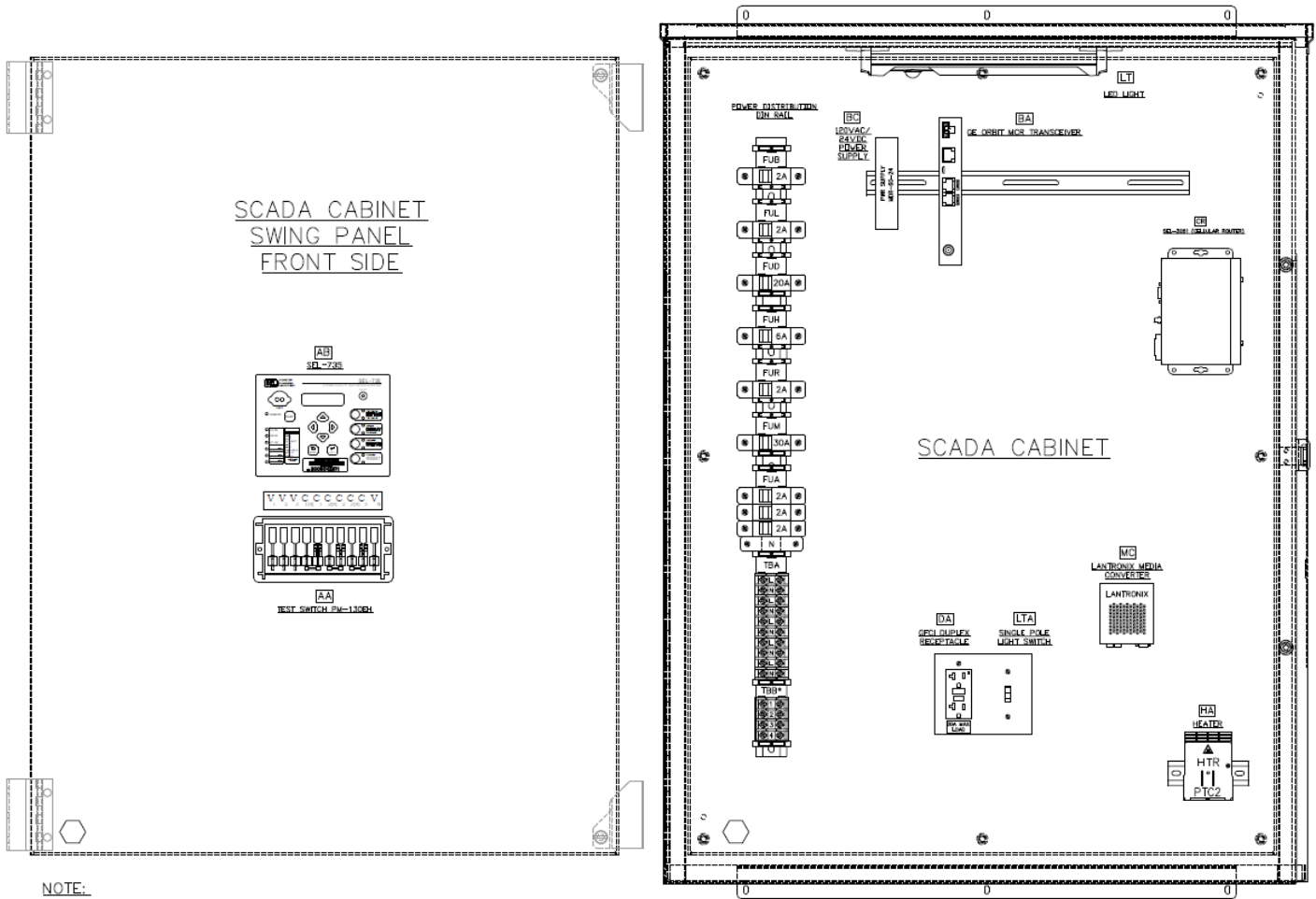

Figure 5: SCADA Cabinet Swing Panel – Rear Side Wiring Diagram



- NOTE:**
1. Install swing panel at least 6" from SCADA cabinet back panel to maintain proper clearance.
 2. Indicated locations of Hoffman Grounding Kit See CSU Electric Substation Standard 8-6 & 8-7

Figure 6: SCADA Cabinet and CPT Enclosure Device Layout

POWER DISTRIBUTION SCHEMATIC

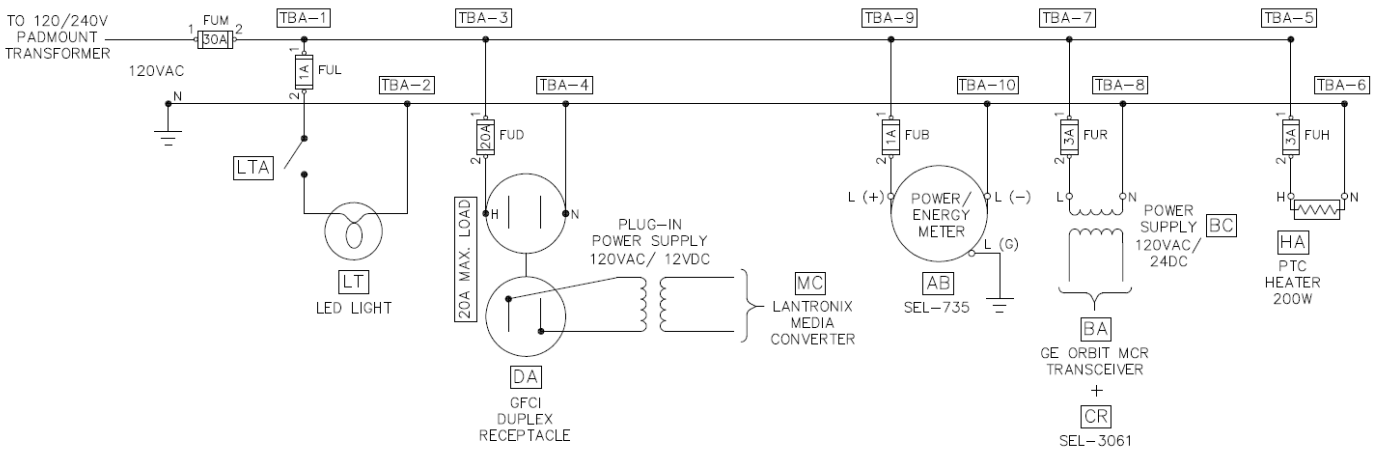

Figure 7: SCADA Cabinet Power Distribution Schematic

7.4 Cabinet

- 7.4.1 The SCADA Panel cabinet compartments and outside enclosures shall be electrically bonded to each other using a quick lug terminals, #6AWG copper wire, and a Hoffman Grounding Kit. The Hoffman Grounding Kit is used to bond the cabinet doors and other cabinet partitions to the back of the enclosure.
- 7.4.2 The solid copper cable grounding electrode for each compartment shall be at least #8-gauge wire size.

7.5 Radio and Antenna

- 7.5.1 Telecom is the governing group for material procurement, equipment testing, and installation for the radio and antenna. This consists from the antenna to the wiring to the local RTU. Telecom has group specific testing and installation procedures consisting of locating the master unit, line loss specifications, etc. Any modification performed on the equipment listed in this section will be under Telecom’s direction and approval. The conduit and fitting will be provided outside of Telecom.

7.6 Construction Safety

- 7.6.1 The external construction shall be such that there are no sharp or jagged edges which could cut, scrape, or injure.
- 7.6.2 The cabinet corners shall be blunted so that piercing or cutting cannot occur during an accidental contact.
- 7.6.3 In general, external design of the SCADA Panel shall be such that it minimizes possible injury to the public.

7.7 Nameplates

7.7.1 Danger/Warning Labels

- 7.7.1.1 Colorado Springs Utilities will furnish and install Danger and Warning Labels on the outside of cabinets per Colorado Springs Utilities Electric Distribution Construction Standard (EDCS) in order to include local phone numbers and other information. The manufacturer shall not furnish nor install exterior danger/warning labels.
- 7.7.1.2 Appropriate danger/warning labels shall be applied to the termination compartments, fuse/interrupter doors, and to the inside of the cabinet doors, and shall be visible after the installation of cable and connectors.

8. Instruction Manuals

- 8.1 Each SCADA Panel shall be provided with detailed instruction manuals to cover the installation, operation, maintenance, and testing of the SCADA Panel. These instructions shall be provided with step-by-step procedures and the necessary drawings, photographs, charts and diagrams.
- 8.2 The manual shall be provided in a clear resealable plastic bag and stored in a permanent storage pocket on the inside of one of the access doors to the cable termination compartments.
- 8.3 A complete set of certified test reports shall be included with the construction manuals.
- 8.4 A complete set of construction drawings shall be included with the manuals.



ELECTRIC STREET CROSSINGS - IN COLORADO SPRINGS CITY LIMITS

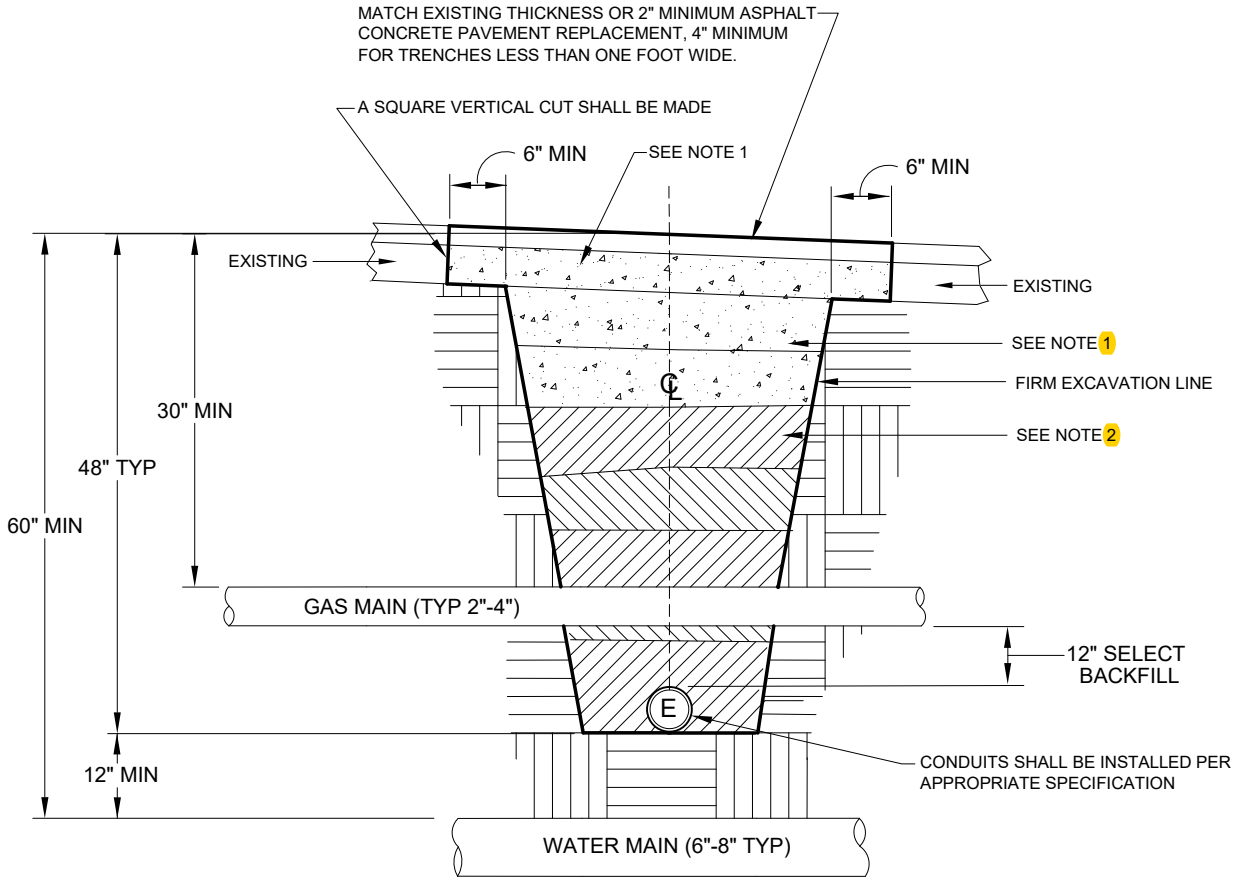

PAVEMENT REPLACEMENT AND BACKFILL DETAIL

STREET CROSSING NOTES:

Deleted notes 1 & 2 and moved note 6 to note 1 position.

1. All work to be in conformance with City of Colorado Springs Public Works specifications (<https://coloradosprings.gov/public-works/page/standard-specifications-manual>), Refer to other authority if using state highway or county roads.
2. When suitable, use native material compacted as specified on page 2. If native soils are not suitable, install flowable fill, Colorado Springs T&D Mix #3 as specified on page 5.
3. Flowable fill is required for street crossing trenches one foot or less in width.
4. Utilize the boring crew/contractor when appropriate for recently repaved streets, etc.

Removed old note 8 about 12" separation between fiber and electric and 3" min from side of trench above encasement.

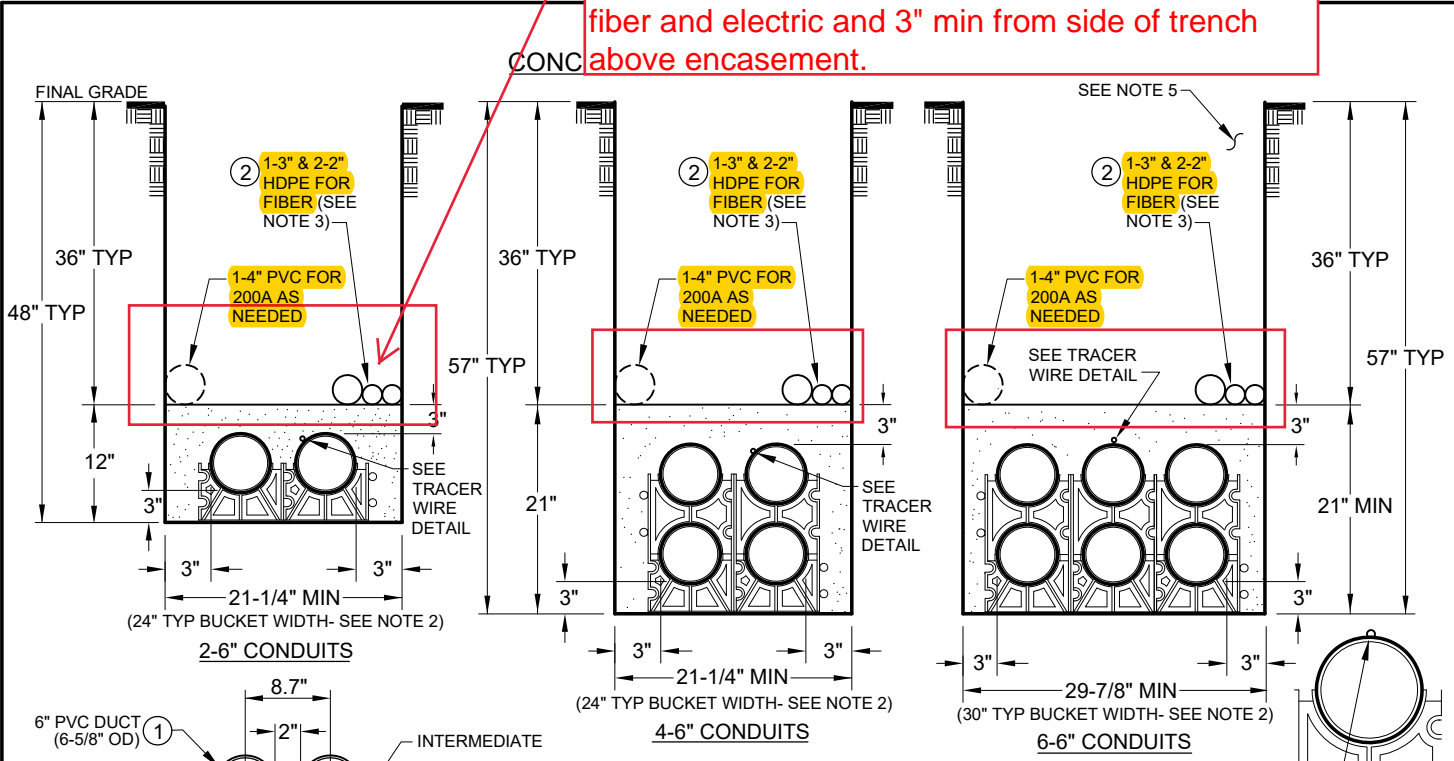

SPACERS		
SIZE	TYPE	ITEM NUMBER
6"	BASE	✓194-212-106
6"	INTERMEDIATE	✓194-212-206

For 3-wide duct structures, #12 CCS tracer wire (Item #292-010-001) shall be taped to top of center duct. For 2 ducts, wire may be taped to inner side of either duct. Tracer wire must be bonded to system ground at each vault or pad location (also see EDCS 11-5 for Street Crossings).

TRACER WIRE DETAIL

✓- Denotes minor material items for all non-100 series items treated as such.

NOTES:

1. Install spacers every 5'. Base spacer and/or intermediate spacers and conduits shall be tied together using line pull polyolefin (Item #194-110-120). Survey stakes shall be used at every base spacer as a tie down to prevent ducts from floating.
2. **Concrete encased** duct is to have a minimum of 3" concrete envelope above and below, and 3" on each side. Dimensions of trench width shall be maintained as shown to keep concrete envelope volume within specification. Any trenches exceeding this limit shall be formed on one side (at contractor's expense) to minimize cost of encasement and excess trench width shall be backfilled at contractor's expense, including all material, labor and equipment costs. Bottom of trench shall be uniform, compact and free of debris.
3. Install **1-3" & 2-2" HDPE** orange conduit for fiber communication cables on top of 3" concrete envelope. Route **fiber** telecommunications duct around outside of electric vaults, on the property side of the vaults. Install telecommunications hand holes near end of vaults as shown on the next page. **Do not use encased duct for communications.**
4. Concrete used for duct encasement shall be "T&D Underground Mix #1" as specified in EDCS 11-1. Concrete shall be properly vibrated when installed to assure complete flow under, around, and between all ducts and to eliminate any air pockets.
5. After concrete has taken firm set, refer to EDCS 11-1 for final backfill and compaction guide using native soil or compaction sand. Backfill of trenches in existing paved streets shall be native soil whenever economical (mechanically compacted per EDCS 11-1, page 2) or if native soil is unsuitable, "T&D Underground Mix #3" as specified in EDCS 11-1, page 5 after concrete encasement has set up. This is a flowable fill that will set up and provide compaction for quick trench closure.
6. NESC Rule 352D requires a minimum of 30" cover above primary cables (601 volts to 50kV); see NESC rules for shallower burial depth requirements. In streets of the city of Colorado Springs, City Code Section 3.3.212 titled "Depth of Structures" requires written permission from the Department of Public Works prior to installation of any structure (except manholes, vaults, and such) at a vertical depth of less than 24" below the established flow line of the nearest gutter (or surface of the nearest outermost edge of the traveled portion of the street).
7. Encasement should be used for 1) 600 amp mainlines, 15kV and 35kV; 2) multiple-duct banks (vertically stacked); 3) installations that require flowable fill or 4) in cases where minimum cover is not met (see EDCS 11-1).
8. Joint trench with fiber must not use the same color scheme as Utilities' standard color for electric, gas, water and wastewater conduit or pipe to avoid confusion for installation and maintenance of trench. Utilities' electric and gas standard colors to avoid are grey, black with red stripes and yellow. Reference Utilities water and wastewater standards for approved colors.

Removed old note 8 about 12" separation between fiber and electric

Removed text about fiber in 6" ducts.

CONCRETE ENCASED DUCT BANKS

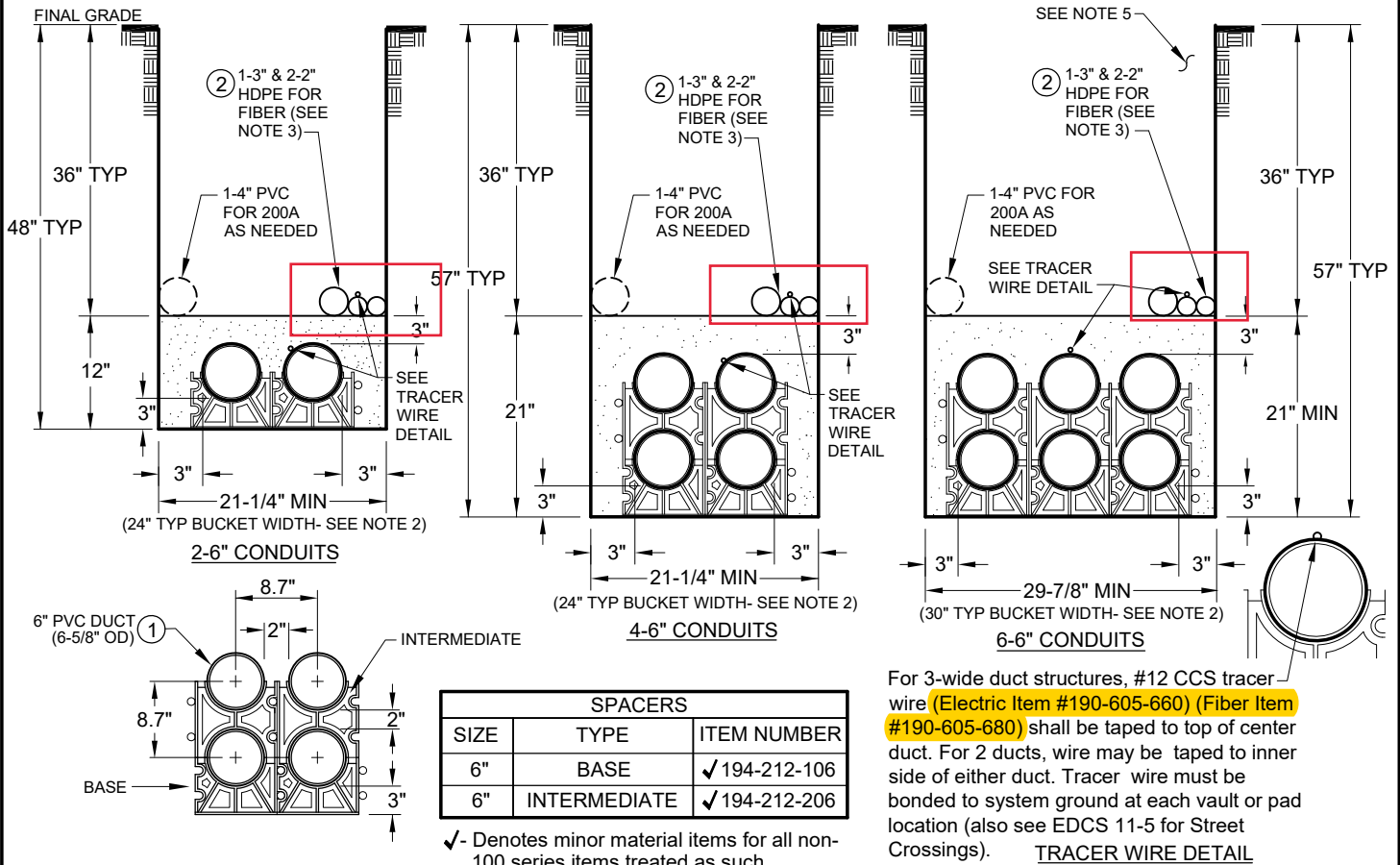

For 3-wide duct structures, #12 CCS tracer wire (Electric Item #190-605-660) (Fiber Item #190-605-680) shall be taped to top of center duct. For 2 ducts, wire may be taped to inner side of either duct. Tracer wire must be bonded to system ground at each vault or pad location (also see EDCS 11-5 for Street Crossings). **TRACER WIRE DETAIL**

NOTES:

1. Install spacers every 5'. Base spacer and/or intermediate spacers and conduits shall be tied together using line pull polyolefin (Item #194-110-120). Survey stakes shall be used at every base spacer as a tie down to prevent ducts from floating.
2. Concrete encased duct is to have a minimum of 3" concrete envelope above and below, and 3" on each side. Dimensions of trench width shall be maintained as shown to keep concrete envelope volume within specification. Any trenches exceeding this limit shall be formed on one side (at contractor's expense) to minimize cost of encasement and excess trench width shall be backfilled at contractor's expense, including all material, labor and equipment costs. Bottom of trench shall be uniform, compact and free of debris.
3. Install 1-3" & 2-2" HDPE orange conduit for fiber communication cables on top of 3" concrete envelope. Route fiber telecommunications duct around outside of electric vaults, on the property side of the vaults. Install telecommunications hand holes near end of vaults as shown on the next page. Do not use encased duct for communications. **Do not introduce communication conduits into any electric vaults. See EDCS 11-5 for Fiber Tracer Wire.**
4. Concrete used for duct encasement shall be "T&D Underground Mix #1" as specified in EDCS 11-1. Concrete shall be properly vibrated when installed to assure complete flow under, around, and between all ducts and to eliminate any air pockets.
5. After concrete has taken firm set, refer to EDCS 11-1 for final backfill and compaction guide using native soil or compaction sand. Backfill of trenches in existing paved streets shall be native soil whenever economical (mechanically compacted per EDCS 11-1, page 2) or if native soil is unsuitable, "T&D Underground Mix #3" as specified in EDCS 11-1, page 5 after concrete encasement has set up. This is a flowable fill that will set up and provide compaction for quick trench closure.
6. NESC Rule 352D requires a minimum of 30" cover above primary cables (601 volts to 50kV); see NESC rules for shallower burial depth requirements. In streets of the city of Colorado Springs, City Code Section 3.3.212 titled "Depth of Structures" requires written permission from the Department of Public Works prior to installation of any structure (except manholes, vaults, and such) at a vertical depth of less than 24" below the established flow line of the nearest gutter (or surface of the nearest outermost edge of the traveled portion of the street).
7. Encasement should be used for 1) 600 amp mainlines, 15kV and 35kV; 2) multiple-duct banks (vertically stacked); 3) installations that require flowable fill or 4) in cases where minimum cover is not met (see EDCS 11-1).
8. Joint trench with fiber must not use the same color scheme as Utilities' standard color for electric, gas, water and wastewater conduit or pipe to avoid confusion for installation and maintenance of trench. Utilities' electric and gas standard colors to avoid are grey, black with red stripes and yellow. Reference Utilities water and wastewater standards for approved colors.

CONCRETE ENCASED DUCT BANKS

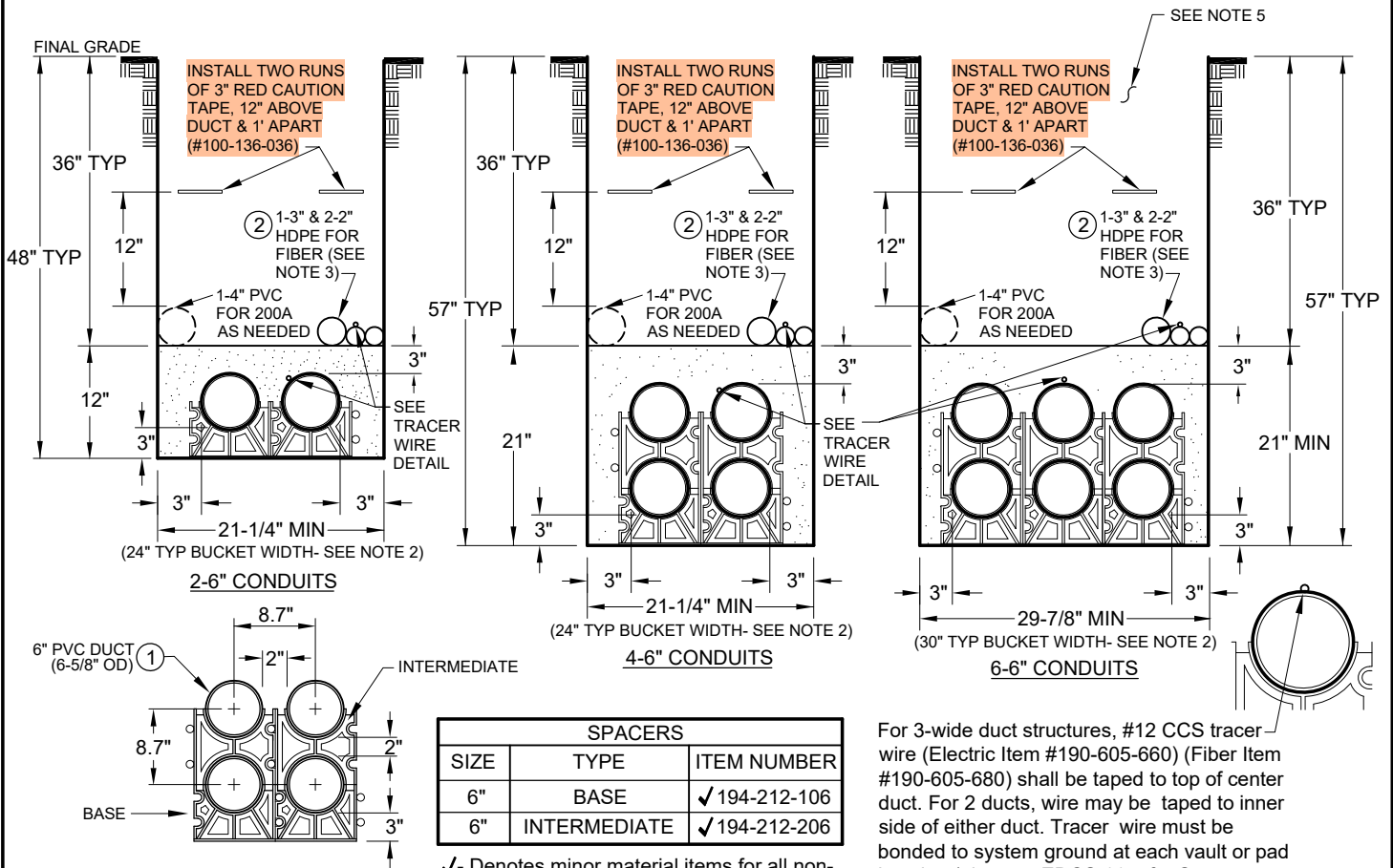

NOTES:

1. Install spacers every 5'. Base spacer and/or intermediate spacers and conduits shall be tied together using line pull polyolefin (Item #194-110-120). Survey stakes shall be used at every base spacer as a tie down to prevent ducts from floating.
2. Concrete encased duct is to have a minimum of 3" concrete envelope above and below, and 3" on each side. Dimensions of trench width shall be maintained as shown to keep concrete envelope volume within specification. Any trenches exceeding this limit shall be formed on one side (at contractor's expense) to minimize cost of encasement and excess trench width shall be backfilled at contractor's expense, including all material, labor and equipment costs. Bottom of trench shall be uniform, compact and free of debris.
3. Install 1-3" & 2-2" HDPE orange conduit for fiber communication cables on top of 3" concrete envelope. Route fiber telecommunications duct around outside of electric vaults, on the property side of the vaults. Install telecommunications hand holes near end of vaults as shown on the next page. Do not use encased duct for communications. Do not introduce communication conduits into any electric vaults. See EDCS 11-5 for Fiber Tracer Wire.
4. Concrete used for duct encasement shall be "T&D Underground Mix #1" as specified in EDCS 11-1. Concrete shall be properly vibrated when installed to assure complete flow under, around, and between all ducts and to eliminate any air pockets.
5. After concrete has taken firm set, refer to EDCS 11-1 for final backfill and compaction guide using native soil or compaction sand. Backfill of trenches in existing paved streets shall be native soil whenever economical (mechanically compacted per EDCS 11-1, page 2) or if native soil is unsuitable, "T&D Underground Mix #3" as specified in EDCS 11-1, page 5 after concrete encasement has set up. This is a flowable fill that will set up and provide compaction for quick trench closure.
6. NESC Rule 352D requires a minimum of 30" cover above primary cables (601 volts to 50kV); see NESC rules for shallower burial depth requirements. In streets of the city of Colorado Springs, City Code Section 3.3.212 titled "Depth of Structures" requires written permission from the Department of Public Works prior to installation of any structure (except manholes, vaults, and such) at a vertical depth of less than 24" below the established flow line of the nearest gutter (or surface of the nearest outermost edge of the traveled portion of the street).
7. Encasement should be used for 1) 600 amp mainlines, 15kV and 35kV; 2) multiple-duct banks (vertically stacked); 3) installations that require flowable fill or 4) in cases where minimum cover is not met (see EDCS 11-1).
8. Joint trench with fiber must not use the same color scheme as Utilities' standard color for electric, gas, water and wastewater conduit or pipe to avoid confusion for installation and maintenance of trench. Utilities' electric and gas standard colors to avoid are grey, black with red stripes and yellow. Reference Utilities water and wastewater standards for approved colors.

CONCRETE ENCASED DUCT BANKS

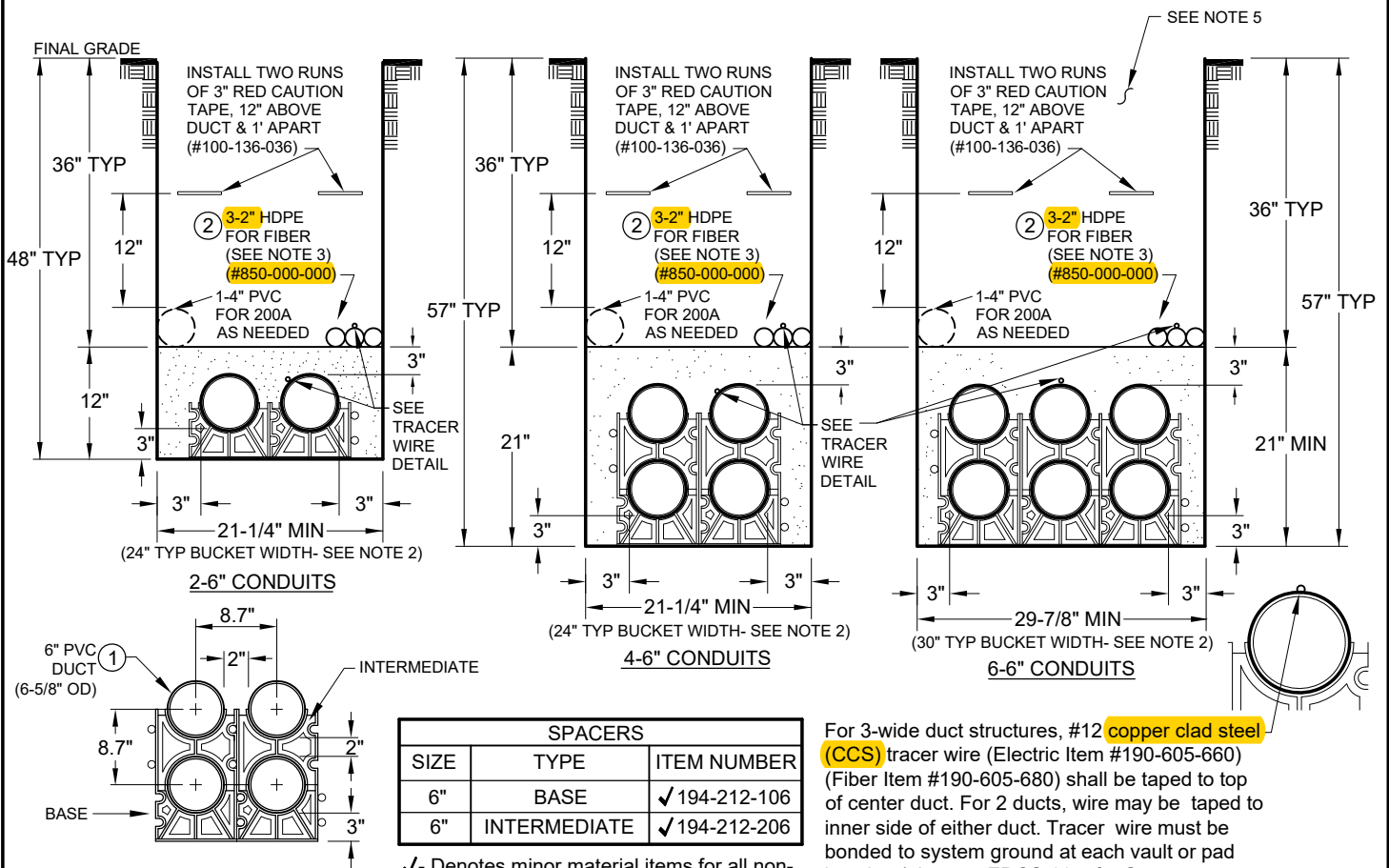

For 3-wide duct structures, #12 copper clad steel (CCS) tracer wire (Electric Item #190-605-660) (Fiber Item #190-605-680) shall be taped to top of center duct. For 2 ducts, wire may be taped to inner side of either duct. Tracer wire must be bonded to system ground at each vault or pad location (also see EDCS 11-5 for Street Crossings).

TRACER WIRE DETAIL

NOTES:

1. Install spacers every 5'. Base spacer and/or intermediate spacers and conduits shall be tied together using line pull polyolefin (Item #194-110-120). Survey stakes shall be used at every base spacer as a tie down to prevent ducts from floating.
2. Concrete encased duct is to have a minimum of 3" concrete envelope above and below, and 3" on each side. Dimensions of trench width shall be maintained as shown to keep concrete envelope volume within specification. Any trenches exceeding this limit shall be formed on one side (at contractor's expense) to minimize cost of encasement and excess trench width shall be backfilled at contractor's expense, including all material, labor and equipment costs. Bottom of trench shall be uniform, compact and free of debris.
3. Install 3-2" HDPE orange conduits for fiber communication cables on top of 3" concrete envelope. Route fiber conduits around outside of electric vaults, on the property side of the vaults. Install communication hand holes near vaults as shown on the next page. Do not use encased ducts for communications. Do not introduce fiber conduits into any electric vaults. See EDCS 11-5 for Fiber Tracer Wire.
4. Concrete used for duct encasement shall be "T&D Underground Mix #1" as specified in EDCS 11-1. Concrete shall be properly vibrated when installed to assure complete flow under, around, and between all ducts and to eliminate any air pockets.
5. After concrete has taken firm set, refer to EDCS 11-1 for final backfill and compaction guide using native soil or compaction sand. Backfill of trenches in existing paved streets shall be native soil whenever economical (mechanically compacted per EDCS 11-1, page 2) or if native soil is unsuitable, "T&D Underground Mix #3" as specified in EDCS 11-1, page 5 after concrete encasement has set up. This is a flowable fill that will set up and provide compaction for quick trench closure.
6. NESC Rule 352D requires a minimum of 30" cover above primary cables (601 volts to 50kV); see NESC rules for shallower burial depth requirements. In streets of the city of Colorado Springs, City Code Section 3.3.212 titled "Depth of Structures" requires written permission from the Department of Public Works prior to installation of any structure (except manholes, vaults, and such) at a vertical depth of less than 24" below the established flow line of the nearest gutter (or surface of the nearest outermost edge of the traveled portion of the street).
7. Encasement should be used for 1) 600 amp mainlines, 15kV and 35kV; 2) multiple-duct banks (vertically stacked); 3) installations that require flowable fill or 4) in cases where minimum cover is not met (see EDCS 11-1).
8. Joint trench with fiber must not use the same color scheme as Utilities' standard color for electric, gas, water and wastewater conduit or pipe to avoid confusion for installation and maintenance of trench. Utilities' electric and gas standard colors to avoid are grey, black with red stripes and yellow. Reference Utilities water and wastewater standards for approved colors.

NOTES:

1. Tracer wire, electronic markers, and j-box shall be installed for locating empty street crossings, conduit stubs, or street light stubs.
2. String wire the entire length of street crossing, or conduit stub. Leave approximately 5-7 feet of slack on one end for attaching to electronic marker in j-box. Train 8" of this tail above electronic marker at inside of j-box. Wrap tracer wire(s) around electronic marker spoke as shown in detail above. Attach tracer wire to marker at opposite end of conduit in the same manner. Attach tracer wire to conduit with electrical tape at each end and every 5 feet. This is required to maintain alignment with the conduit. Install j-box a minimum 24" behind future curbing, and 2" above grade. Provide conduit size on dymo tape and attach to end of tracer wire at enclosure for future identification as shown in detail above.
3. If two Colorado Springs Utilities electric conduits are both installed in the same trench within 18" maximum separation (to outside), only one tracer wire is required. Attach tracer wire to largest OD conduit per note 2. Place marker 6" above and centered between conduits. Identify both conduits on dymo label. Provide 6" minimum separation between conduits to ensure good compaction (see End View detail above). For separation greater than 18" to outside of conduits, install tracer wire on each duct and label individually.
4. Plastic j-box and electronic markers shall be removed for re-use after cable has been installed. Tracer wire can be abandoned at this time.
5. Repair splices of #12 CCS tracer wire may be made with connector (Item #100-112-100) insulated with mastic, wrapped with electrical tape.

FIBER CONDUIT

GENERAL:

1. Fiber conduit must be installed with a tracer wire on the center-most duct which is used as a means of locating the conduit while it is underground.
2. Open trench applications will use a #12, high-strength, copper-clad steel, wire with a orange, HDPE jacket (Item 190-605-680). See Table on page 1.
3. Directional boring applications will use a #12, extra high-strength, copper-clad steel, wire with a orange, HDPE jacket (Item 190-605-691). See Table on page 1.
4. The ends of tracer wire are to be wrapped first with a 3/4" rubber splicing tape (100-136-070) and then 3/4" electrical tape (100-136-100) for protection.
5. Tracer wire should not be wrapped around the duct.
6. In trench applications, the tracer wire is to be placed on top of the center duct only and is to be taped to the duct in at least 3 locations and not to exceed 10 feet apart between tapes.

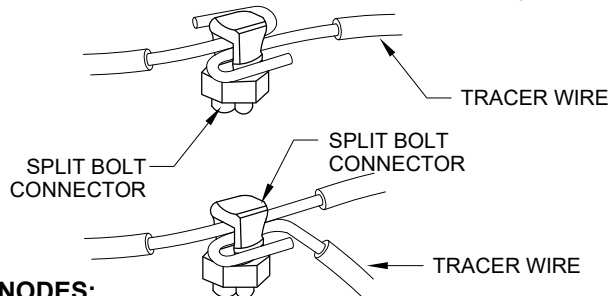

ANODES:

1. For long runs of duct, a 1 lb. anode will be attached to the tracer wire every 1000 ft.
2. To protect the tracer wire used to assist in PE pipe locating, a 1lb. anode (201-000-001) should be connected to the end of the tracer wire for all new dead end conduit runs. The new anode will be attached to the tracer wire with a split-bolt connector (212-000-009). The connector is to be wrapped first with a 3/4" rubber splicing tape (100-136-070) and then 3/4" electrical tape (100-136-100) for protection.
3. The installation or removal of a tracer wire anode must be noted in the permanent field record.
4. The appropriate clearances between anodes and steel pipes or other structures must be maintained.
5. This is similar to the Gas Design and Engineering Manual for tracer wire installation.

SPLICING:

1. Tracer wire should be as continuous as possible. Where splicing is necessary, the only approved method is to use a split bolt connector (212-000-009).
2. Once installed, the connectors should first be wrapped with a 3/4" rubber splicing tape (100-136-070) and then 3/4" electrical tape (100-136-100) for protection.

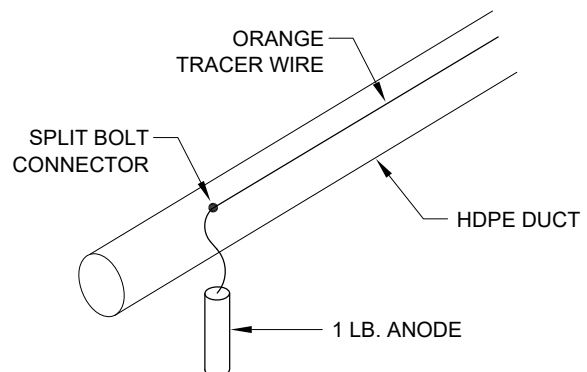

Typical Parallel/Horizontal Clearance Matrix for Colorado Springs Underground Utilities (Separate Trenches):

(All dimensions are in feet) All separations shown are the clear horizontal distance between two objects measured surface to surface

Colorado Springs Utilities (Underground)	Potable Water	Non-Potable Water	Waste-water	Storm Sewer	Gas mains 150 psig (MAOP)	Gas main	Gas Service	Electric Primary up to 34.5kV	Electric Secondary (0-480 Volt)	Telecom / Fiber
Potable Water	X	10	10	10 ^c	10	6	3	10 ^d	3	5
Non-Potable Water	10	X	10	10	10	6	3	10	3	5
Wastewater	10	10	X	10 ^c	10	6	3	10 ^d	3	5
Storm Sewer	10 ^c	10	10 ^c	X	10	6	3	10	3	5
Gas mains 150 psig (MAOP)	10	10	10	10	X	6	6	10	10	10
Gas main	6	6	6	6	6	X	3	6	3	5 ^e
Gas Service	3	3	3	3	6	3	X	3	3	3
Electric Primary up to 34.5kV	10 ^d	10	10 ^d	10	10	6	3	X	3	5 ^e
Electric Secondary (0-480 Volt)	3	3	3	3	10	3	3	3	X	5 ^e
Telecom / Fiber	5	5	5	5	10	5 ^e	3	5 ^e	5 ^e	X

Typical Crossings/Vertical Clearance Matrix for Colorado Springs Underground Utilities:

(All dimensions are in feet) All separations shown are the clear vertical distance between two objects measured surface to surface

Colorado Springs Utilities (Underground):	Potable Water	Non-Potable Water	Waste-water	Storm Sewer	Gas mains 150 psig (MAOP)	Gas main	Gas Service	Electric Primary up to 34.5kV	Electric Secondary (0-480 Volt)	Telecom / Fiber
Potable Water	X	1.5 ^a	1.5 ^a	1.5 ^a	5	1	1	1	1	1
Non-Potable Water	1.5 ^a	X	1.5 ^a	1.5 ^a	5	1	1	1	1	1
Wastewater	1.5 ^a	1.5 ^a	X	1.5	5	1	1	1	1	1
Storm Sewer	1.5 ^a	1.5 ^a	1.5 ^a	X	5	1	1	1	1	1
Gas mains 150 psig (MAOP)	5	5	5	5	X		5	5	5	5
Gas main	1	1	1	1		X	1	1/5 ^b	1	1
Gas Service	1	1	1	1	5	1	X	1	1	1
Electric Primary up to 34.5kV	1	1	1	1	5	1/5 ^b	1	X	0	1
Electric Secondary (0-480 Volt)	1	1	1	1	5	1	1	0	X	1
Telecom / Fiber	1	1	1	1	5	1	1	1	1	X

^a These utilities require a sleeve when crossing under another utility.

^b 1' separation from electric primary to plastic pipe gas main and 3' separation from electric primary to metallic gas main.

^c Exception: Minimum 5' separation if meets the means of secondary containment listed in the Water Line Extension and Service Standards Book 2.6.F.2 Separation Criteria and Wastewater Line Extension and Service Standards Book 2.5.D.2 Separation Criteria.

^d Exception: Minimum 6'-10" clearance from Electric Primary to Potable Water and Wastewater.

^e Exception: ~~In scenarios where the gas main and electric primary or secondary is behind the curb and either in the tree lawn or under sidewalk, 3 feet of horizontal separation between telecom/fiber and gas mains, electric primary, or electric secondary, may be permitted. The exception may be allowed when the following requirements are met: 1) potholing and exposing the pipe every 50 feet must occur when directional drilling is within 5 feet of the gas or electric pipe; 2) potholing and exposing the pipe every 25 feet is required when pneumatic missiles/moles are used within 5 feet of the gas or electric pipe; 3) for bores less than 50 feet and within 5 feet of the gas or electric pipe (regardless of trenchless technology used), a minimum of one pothole is required; 4) potholing and exposing the gas or electric pipe where points of typical deviation may occur (e.g., hydrants, transformers, etc.) and 5) compliance with all State and local excavation, boring, and damage prevention rules and regulations. Telecom/fiber may be permitted to have a 3' horizontal separation from gas mains, electric primary or electric secondary in locations where the gas main and electric primary or secondary are behind the curb and either in the tree lawn or under sidewalk. The exception may be allowed when the following requirements are met:~~

- 1) potholing and exposing the pipe every 50 feet must occur when directional drilling is within 5 feet of the electric or gas pipe;
- 2) the use of pneumatic missiles must be in compliance with City Policy and may prohibit the use of pneumatic methods for



ELECTRIC DISTRIBUTION CONSTRUCTION STANDARDS

APPROVED AS OF:
9-6-2024

CLEARANCES OF UG ELECTRIC CONDUIT/CABLE FROM OTHER FACILITIES

18-304 PG.3/4

installation of underground utilities in the right-of-way and public utility/improvement easements. If the City Policy does allow for the use of pneumatic methods to install underground utilities, then potholing and exposing pipe every 25 feet is required when pneumatic missiles/moles are used within 5 feet of electric or gas pipe;

3) for bores less than 50 feet and within 5 feet of electric or gas pipe (regardless of trenchless technology used), a minimum of one pothole is required;

4) potholing and exposing electric or gas pipe where points of typical deviation may occur (e.g., hydrants, transformers, etc.) and;

5) compliance with all State and local excavation, boring, and damage prevention rules and regulations.

All other scenarios must comply with clearance requirements in the matrix table above. If any one of the 5 listed requirements are not met, a 5-foot clearance is required. In all cases, the high pressure gas main requires a 10-foot horizontal clearance with no exceptions. The horizontal clearance distance also applies to fiber appurtenances, to include boxes (boxes must be the required horizontal and vertical distance away from gas and electric and shall not be placed over electric or gas pipe.)

See notes on next page.

1. If compliance with these separation requirements, or those set forth in the Clearance Matrix cannot be met they will be addressed on a case-by-case basis following variance procedures described in the applicable Line Extension and Service Standard book. This includes areas of redevelopment within alleys. Colorado Springs Utilities subject matter experts for the utility being impacted will make the determination regarding clearances.
2. These clearance matrix table dimensions are for separate trenches. Joint trench between Gas and Colorado Springs Utilities Telecom./Fiber requires a 1' radial separation. Joint trench between Electric and Colorado Springs Utilities Telecom./Fiber requires a 3" in concrete and 6" in fill earth radial separation.
3. See the Gas Line Extension and Service Standards 2.02c for certain exceptions.
4. See Water & Wastewater Line Extension and Service Standards, latest edition.
5. Clearance to other Colorado Springs utilities (telecommunication, fiber optics, etc.) or high voltage underground transmission cables shall be determined on a case-by-case basis by Field Engineering.
6. Storm Sewer clearances must be verified by City Engineering.
7. Larger clearances than shown may be required – clearances must meet all requirements set forth in all four of the Colorado Springs Utilities Line Extension and Service Standards, Colorado Springs City Codes, NEC, and NESC, latest editions.
8. Additional support structures may be required at crossings.
9. For separation from trees to gas and electric line, see GLESS 2.02c and ELESS 4.02c1.
10. See City of Colorado Springs Standard Drawings #1 "Street Cross Sections" and Drawings #2 "Street Sections Plan View" at the following web address link: <https://coloradosprings.gov/public-works/page/standard-drawings>



ELECTRIC DISTRIBUTION CONSTRUCTION STANDARDS

APPROVED AS OF:
9-6-2024

CLEARANCES OF UG ELECTRIC CONDUIT/CABLE FROM OTHER FACILITIES

18-304 PG.4/4

**COLORADO SPRINGS UTILITIES
ELECTRIC LINE EXTENSION/SERVICE INSTALLATION**

PHONE NUMBERS & CONTACT INFORMATION

P L A N N I N G

Utilities Development Services 668-8259

Utility Data Management (FIMS)

Land Base Maps & Plat Maps 668-8779

Electric and Street Light GIS Data 668-3524 Opt. 3

Utilities Addressing Plan (UAP) and Utilities Design CAD Files (UDCF) 668-7920

Underground Utility Line Locations

Before you dig (All Utilities, ex: Springs Utilities, phone, cable) - Call 3 business days before digging.....811

Utilities Locating Dispatch (For Colorado Springs Utilities gas, electric, water and wastewater)

Main Number.....668-7205

D E S I G N

Design of Electric Line Extensions & Street Lights (Field Engineering)

Field Engineering Supervisor: Tim BenedictOffice 668-3574.....Cell 661-5505

North Area Main Number.....668-4985 South Area Main Number 668-4985

**North Workcenter Field Engineering
7710 Durant Drive, Colorado Springs, CO 80947-2150/ Fax: 719-668-4998**

Name	Title	Area	Office	Cell
Dylan Quintana	Engineer Support Supervisor	Gas & Joint Trench	719-668-8330	719-675-0099
Tony Gius	Field Engineer	Joint Trench	719-668-3575	719-500-1943
Steve Travnicek	Field Engineer	Gas & Joint Trench	719-668-7716	719-728-3271
Tim Wendt	Field Engineer	Gas & Joint Trench	719-668-4962	719-237-7968
Justin Noel	Field Engineer	Gas	719-668-4872	719-377-0419
Ryan Pogue	Field Engineer	Gas	719-668-7840	719-828-4618
Santiago Tijerina	Field Engineer	Gas	719-668-3572	719-828-1772
Timothy Williams Jr	Field Engineer	Gas	719-668-7276	719-257-8426

**South Workcenter Field Engineering
1521 Hancock Expressway, Colorado Springs, CO 80947-1812/ Fax: 719-668-5956**

Name	Title	Area	Office	Cell
Joe Reuter	Field Engineering Supervisor	Electric	719-668-7885	719-499-5798
Jim Bradbury	Field Engineer	Electric	719-668-3243	719-433-3112
Dave Coker	Field Engineer	Electric	719-668-8796	719-649-2665
Rudy Duran	Field Engineer	Electric	719-668-8762	719-464-7961
Josh Hoepfner	Field Engineer	Electric	719-668-3242	719-322-6048
Kyle Leibhart	Field Engineer	Electric	719-668-8767	719-313-1504
John Martinez	Field Engineer	Electric	719-668-3244	719-323-4778

Street Light Requests Outside City Limits:

Cherokee Metropolitan District Mark Cuchiara 597-5080 1335 Valley Street Colorado Springs, CO 80915 Phone: 597-5080	Green Mountain Falls 7035 Oak Street Green Mountain Falls, CO 80819 Phone: Town Clerk 684-9414 <i>(Closed on Wednesdays)</i>
--	--

C O N S T R U C T I O N

Construction Scheduling	
North Area 668-4991	South Area 668-5557
Inspections (Q.C. – Quality Control) 668-5416	

S E R V I C E I N S T A L L A T I O N

Electric Service Department	
Utilities Electric Meter and Service Installation, Construction Temporary Electric Service Installation & Outage Requests 668-5524	
Joint Trench Gas/Electric Scheduling Inspections and Tie-Ins 668-2TIE (2843)	
Pikes Peak Regional Building Department	
Building Permits 327-2880	
Electrical Inspections..... 327-2883	

O T H E R T E L E P H O N E N U M B E R S

Main Customer Service Number	
Overhead Power-Line Cover, Tree Trimming Near Overhead Electric Power Lines 448-4800	
Damage Claims..... 385-5960	
Energy Construction Operations and Maintenance Department Managers	
Construction and Maintenance ... 668-5957	Operations and Engineering 668-5723
Engineering and Planning	
Demand Side Management and Renewable Energy Planning (Solar/Distributed Generation) 668-7719	
Standards 668-5806	
Substation and Transmission Engineering 668-8361	
General Accounting (Inquiry for Time-and-Material Refunds)..... 668-8550	
Meter Shop (AMT - Advanced Metering Technologies Group)..... 668-5525	
Supervisor 668-3505	
Repairs: Cable & Utility Line/Street Light	
Colorado Springs Utilities Street Light Malfunction..... 448-4800	
Colorado Springs Utilities (Electric, Gas, Water & Wastewater)..... 448-4800	
City Traffic Signals 385-6721	
Comcast (Cable Repair) 633-6616	
CenturyLink Customer Service Repair 1-800-573-1311	
Utility Safety Outreach and Education	
Schedule a free utility safety outreach and education at communityrelations@csu.org 668-8386	
Warehouse	
North Work Center 668-4981	
South Work Center..... 668-5550	

NORTH WORK CENTER
 7710 DURANT DRIVE, P.O. BOX 1103
 MAIL CODE 2150
 COLORADO SPRINGS, CO
 80947-2150
 MAIN PHONE: 668-4985
 FIELD ENGINEERING FAX: 668-4998

TIM BENEDICT
 GAS AND JOINT TRENCH FIELD
 ENGINEERING SUPERVISOR
 668-3574
 661-5505

LINDA ISAACSON
 PLANNER ANALYST SR.
 668-4691

JULIE GROSE
 ADMIN SPEC.
 668-8129

ELECTRIC FIELD ENGINEERS AREAS



ELECTRIC
 TIM WENDT
 668-4962
 237-7968

ELECTRIC
 JIM BRADBURY
 668-3243
 433-3112

ELECTRIC
 JIM BRADBURY
 668-3243
 433-3112

ELECTRIC
 RUDY DURAN
 668-8762
 464-7961

**ELECTRIC/WATER/GAS
 EMERGENCY (ONLY):
 DISPATCH 668-8800
 CUSTOMER SERVICE 448-4800
 ADDRESS: 111 S. CASCADE,
 COLORADO SPRINGS, CO 80903
 HOURS: M-F 7am-7pm / SAT
 8am-12pm
 CALL BEFORE U-DIG: 811**

ELECTRIC
 JOSH HOEPFNER
 668-3242
 322-6048

ELEC
 DOWNTOWN
 NETWORK
 DAVE COKER
 668-8796
 649-2665

ELECTRIC
 KYLE
 LEIBHART
 668-8767
 313-1504

DAVE COKER
 PETERSON SFB,
 CHEYENNE MTN
 SFB, & FT CARSON
 668-8796
 649-2665

JULIE GROSE
 ADMIN SPEC.
 668-8129

ERIC GUNDRUD
 PLANNER ANALYST
 SR. 668-5558

**JOE REUTER
 ELECTRIC FIELD
 ENGINEERING SUPERVISOR**
 668-7885
 499-5798

SOUTH WORK CENTER
 1521 HANCOCK EXPRESSWAY,
 P.O. BOX 1103, MAIL CODE 1812
 COLORADO SPRINGS, CO
 80947-1812
 MAIN PHONE: 668-5564
 FAX: 668-5956

ELECTRIC
 JOHN MARTINEZ
 668-3244
 323-4778

ELEC
 AIRPORT
 DAVE COKER
 668-8796
 649-2665

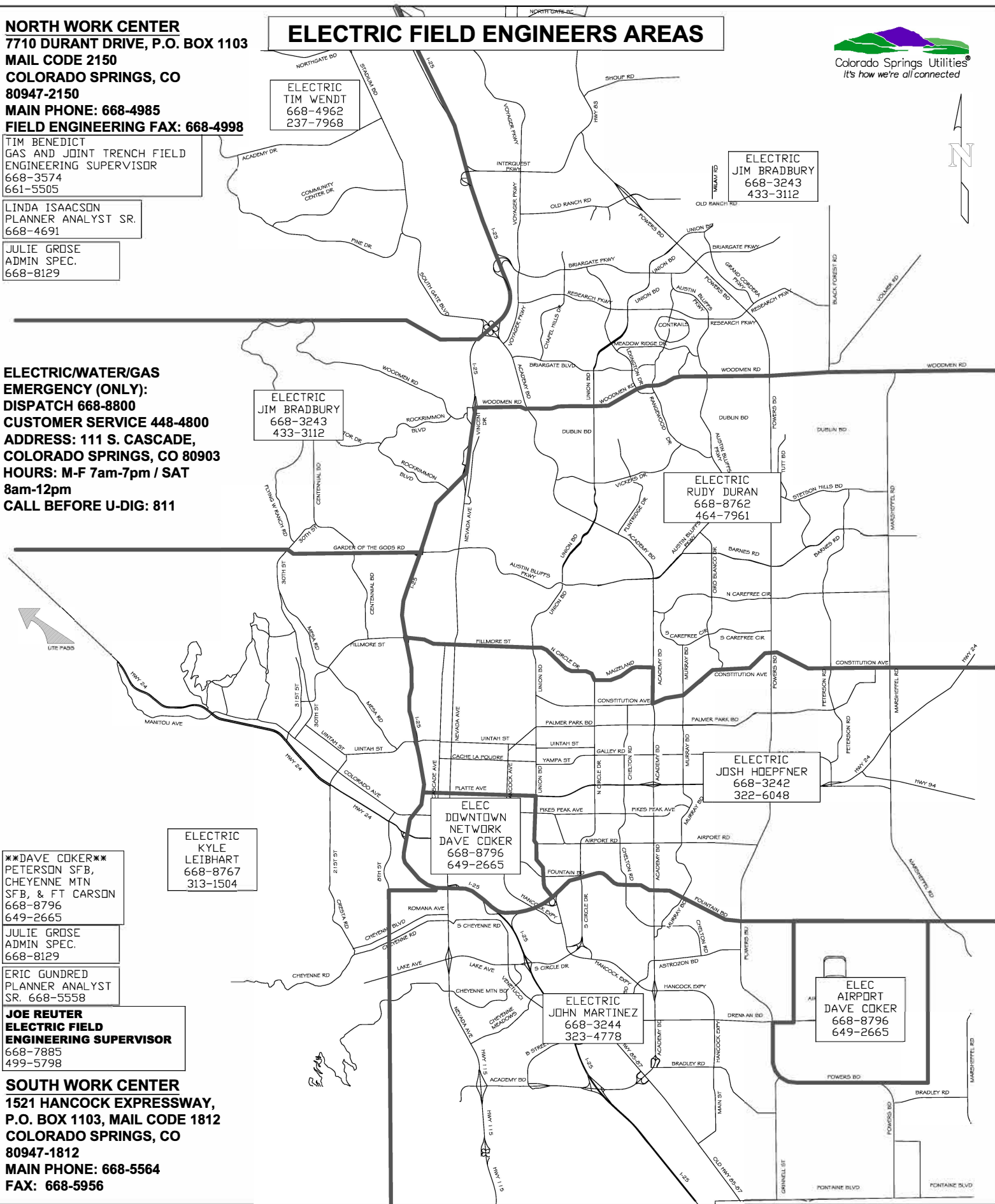

NORTH WORK CENTER
 7710 DURANT DRIVE, P.O. BOX 1103
 MAIL CODE 2150
 COLORADO SPRINGS, CO
 80947-2150
 MAIN PHONE: 668-4985
 FIELD ENGINEERING FAX: 668-4998

TIM BENEDICT
 GAS AND JOINT TRENCH FIELD
 ENGINEERING SUPERVISOR
 668-3574
 661-5505

LINDA ISAACSON
 PLANNER ANALYST SR.
 668-4691

JULIE GROSE
 ADMIN SPEC.
 668-8129

**ELECTRIC/WATER/GAS
 EMERGENCY (ONLY):
 DISPATCH 668-8800
 CUSTOMER SERVICE 448-4800
 ADDRESS: 111 S. CASCADE,
 COLORADO SPRINGS, CO 80903
 HOURS: M-F 7am-7pm / SAT
 8am-12pm
 CALL BEFORE U-DIG: 811**

JULIE GROSE
 ADMIN SPEC.
 668-8129

ERIC GUNDRUD
 PLANNER ANALYST
 SR. 668-5558

JOE REUTER
 ELECTRIC FIELD
 ENGINEERING SUPERVISOR
 668-7885
 499-5798

SOUTH WORK CENTER
 1521 HANCOCK EXPRESSWAY,
 P.O. BOX 1103, MAIL CODE 1812
 COLORADO SPRINGS, CO
 80947-1812
 MAIN PHONE: 668-5564
 FAX: 668-5956

JOINT TRENCH AREA MAP



JOINT TRENCH
 DYLAN QUINTANA
 668-8330
 675-0099

JOINT TRENCH
 TIM WENDT
 668-4962
 237-7968

JOINT TRENCH
 TONY GUIZ
 668-3575
 500-1943

JOINT TRENCH
 STEVE TRAVNICEK
 668-7716
 258-7209

JOINT TRENCH
 TIM WENDT
 668-4962
 237-7968

